



ANALYSIS OF MULTI-SOURCE HEAT PUMP DESIGNED TO HEAT
REQUIREMENT OF BUILDING

Thesis of the doctoral (PhD) dissertation

DOI: 10.54598/002000

Péter Hermanucz

Gödöllő - Hungary

2022

Doctoral school denomination: Doctoral School of Mechanical Engineering

Science: Mechanical Engineering

Head of school: Prof. Dr. Gábor Kalácska, DSc
Institute of Technology
Hungarian University of Agriculture and Life Science, Gödöllő - Hungary

Supervisor: Prof. Dr. István Barótfi, CSc
Institute of Technology
Hungarian University of Agriculture and Life Science, Gödöllő - Hungary

Co-Supervisor: Dr. Gábor Géczi, PhD
Institute of Environmental Engineering
Faculty of Mechanical Engineering
Hungarian University of Agriculture and Life Science, Gödöllő – Hungary

.....

Affirmation of head of school

.....

Affirmation of supervisor

CONTENTS

LIST OF SYMBOLS	5
1 INTRODUCTION.....	7
1.1 Relevance and significance of the topic	7
1.2 Objectives	8
2 MATERIAL AND METHOD.....	9
2.1 The measuring devices	9
<i>2.1.1 Physical model of a multi-source heat pump</i>	<i>9</i>
<i>2.1.2 Equipment used for the defrost cycle test.....</i>	<i>13</i>
<i>2.1.3 Instrumentation of multi-source heat pumps.....</i>	<i>14</i>
<i>2.1.4 Instrumentation of the equipment used to test the defrost cycle... </i>	<i>15</i>
2.2 Applied measurement settings.....	16
<i>2.2.1 Settings for dual heat source heat pump</i>	<i>16</i>
<i>2.2.2 Settings used to test defrost cycles.....</i>	<i>17</i>
2.3 Evaluation methods.....	17
<i>2.3.1 Defining characteristics that are difficult to measure.....</i>	<i>17</i>
<i>2.3.2 Power ratio of evaporators of multi-source heat pumps.....</i>	<i>18</i>
<i>2.3.3 Data recording, remote access.....</i>	<i>18</i>
<i>2.3.4 Mathematical background for data evaluation</i>	<i>19</i>
<i>2.3.5 Determination of defrost cycle times.....</i>	<i>19</i>
3 RESULTS.....	20
3.1 Experimental results of a multi-source heat pump system.....	20
<i>3.1.1 Test of simultaneous, parallel operation of an air and water heat source.....</i>	<i>20</i>
<i>3.1.2 Adjusting the power ratio of evaporators operating in parallel with a pressure control valve</i>	<i>21</i>
<i>3.1.3 Power ratio of evaporators operating in parallel without regulation.....</i>	<i>22</i>
<i>3.1.4 Comparison of regulated and self-adjusting systems.....</i>	<i>25</i>
<i>3.1.5 Features modeled in software and their comparison with the measurement results.....</i>	<i>26</i>

3.2 Defrost cycle measurement results	29
3.2.1 <i>Evaluation of the measurement results of the defrost cycle</i>	29
3.2.2 <i>A way to reduce annual power outages by using an additional heat source</i>	32
3.3 New scientific results.....	34
4 SUMMARY.....	37
5 MOST IMPORTANT PUBLICATIONS RELATED TO THE THESIS..	39

LIST OF SYMBOLS

E	a constant characteristic of refrigerants	[min]
h_1	enthalpy value at the compressor suction port	[kJ kg ⁻¹]
h_2	enthalpy value at the compressor discharge port	[kJ kg ⁻¹]
h_3	enthalpy value before the expansion valve	[kJ kg ⁻¹]
h_5	enthalpy value after the air heat source evaporator	[kJ kg ⁻¹]
h_6	enthalpy value after the water heat source evaporator	[kJ kg ⁻¹]
k	water-to-air heat source power ratio	[-]
L	a constant characteristic of the refrigerant	[-]
\dot{m}_{Rair}	mass flow of evaporative refrigerant in the air	[g s ⁻¹]
\dot{m}_{Rwater}	mass flow of water heat source evaporative refrigerant	[g s ⁻¹]
\dot{m}_R	condenser refrigerant mass flow	[g s ⁻¹]
P_{evap}	evaporation pressure input field in Solkane 7 software	[kPa]
P_1	pressure at compressor intake manifold	[kPa]
P_2	pressure at compressor discharge port	[kPa]
P_3	pressure in the condenser	[kPa]
P_{E5}	pressure in the air source heat evaporator	[kPa]
P_{E6}	pressure in the water heat evaporator	[kPa]
$P_{electricl}$	the absorbed electrical power of the compressor	[W]
\dot{Q}_{water}	heat output of water heat source evaporator	[W]
\dot{Q}_{air}	heat output of an air heat source evaporator	[W]
Q_K	condenser heat output	[W]
Q_{evap}	evaporative heat. input field in Solkane 7 software	[W]
Q_H	thermal energy introduced to the system	[W]
Q_{be}	amount of heat introduced	[W]
Q_c	total heat energy flowing from the system to the cold tank	[W]
Q_{ki}	evaporation heat amount	[W]
Q_e	evaporator performance	[W]
RH	relative humidity	[%]
S_A	the entropy of the compressed gas	[J K ⁻¹]
S_B	the entropy of the expanded gas	[J K ⁻¹]
T_1	vapour temperature at the compressor suction port	[°C]
T_2	vapour temperature at the compressor discharge port	[°C]
T_3	fluid temperature in front of the expansion valve	[°C]
T_5	vapour temperature after the air heat source evaporator	[°C]
T_6	vapour temperature after the water heat source evaporator	[°C]
T_a	Outdoor air temperature	[°C]

List of symbols

T_a	Outdoor air temperature	[°C]
t_{cycle}	operating cycle length	[min]
t_{down}	downtime due to defrost cycles	[min]
$t_{defrost}$	defrost cycle length	[min]
t_{opt}	optimal operating time between two defrost cycles	[min]

T_H	the absolute temperature of the hot tank	[K]
V	volume	[m ³]
W	compression work	[kJ]
X	downtime rate due to defrost cycles	[-]
y_i	the i-th measured value	
\hat{y}	the value of the fitted function for the given value of x	

Greek symbols

η	efficiency of the system	[-]
--------	--------------------------	-----

Abbreviations

SCOP	Seasonal performance factor
COP	Effective power factor
EVI	Economised vapour injection
PID	Proportional-Integrating-Differential governor
COP_{ind}	Indicated power factor
EER	Energy efficiency ratio
RMSE	root of mean square error
GWP	Global warming potential
ODP	Ozone depletion potential
TEWI	Total equivalent warming impact

1 INTRODUCTION

In my doctoral dissertation, I mainly study the possibilities of the simultaneous, parallel utilization of two heat sources in the case of heat pumps for heating purposes, as well as the power loss caused by the de-icing of evaporators utilizing the air heat source.

1.1 Relevance and significance of the topic

Reducing the energy use of newly built residential properties is an important goal from an energy and environmental point of view. The heat demand for heating is decreasing with the modernization of buildings, and low-temperature heating systems, which are increasingly fed by heat pumps, are coming to the fore. At the same time, the amount of energy spent on domestic hot water production and the level of temperature remained almost unchanged, so their ratio shifted in favor of hot water production. This phenomenon fundamentally reshapes the time distribution and temperature level of energy use in residential buildings, which on the one hand favors the use of heat pumps and on the other hand is difficult to serve optimally by using a heat source. Due to the fact that with the aforementioned rearrangement of the energy needs of residential buildings, there is a significant heat demand even at higher outdoor temperatures, a maximum seasonal performance factor (SCOP) cannot be achieved independently based on an air or ground heat source.

Refrigeration technology has a longer tradition than heat pumping for heating purposes, but the possibility that the process can be reversed - rather, the “hot side” of the process is considered useful - has been around for quite some time (Komondy, 1952), but technology and energy prices moreover, due to the thermal energy required at higher temperatures, these were not widespread. Presumably, however, due to the development of energy prices, there has been a smaller decline, and after the turn of the millennium, it is experiencing a renaissance that continues to this day, and is gaining ground due to changes in employment conditions, as shown in Figure 1.1. Figure (Eurostat, 2021). The vast majority of heat pumps basically utilize the heat content of the soil using ambient air or water. The utilization of ground heat at basically low outdoor temperatures is an advantage, as its temperature is higher than air here, and defrost cycles do not affect performance either.

The air heat source is preferably used at temperatures above 10 ° C, since no reduction in power due to defrost cycles is to be expected. At high outdoor temperatures, a higher evaporation temperature can be achieved compared to the use of ground heat by using an air heat source.

1.2 Objectives

My assumption is that by combining the available technical solutions and using several evaporators, the operation of the heat pump can be adapted to the heat sources available at a given time and to the heat demand. I examine the switching and control methods of heat exchangers, as well as the software modeling procedures. In my dissertation I examine the structure of heat pump types that are suitable for the heat demand of residential buildings in practice, and then I propose the possibilities of using two heat sources within one system. Using the data obtained by establishing a physical model and performing a series of measurements, I present a solution to further develop the available software modeling capabilities.

I examine separately the defrost cycles of currently used monoenergetic heat pumps with an air heat source, which I suggest reduces the average power available with a given machine size. I also analyze the extent of this and the possibilities to avoid it, which leads to the advantageous properties of the two heat source heat pumps I propose.

2 MATERIAL AND METHOD

In this chapter I describe the operation of the equipment and measuring systems I use, as well as the methods and relationships used in data processing. Given that I used two measuring systems in my work, I present their structure, instrumentation and operation in separate chapters.

2.1 The measuring devices

My research went in two directions: on the one hand, I determined the power loss caused by the defrost cycles of air source heat pumps, for which I built a test equipment. On the other hand, I created a physical model of the two heat source heat pumps with modifications, which made it possible to perform scientifically demanding cooling circuit tests. The primary reason for this is that measurements are usually made on real, operating heating systems, or minor changes are made to them. In these systems, the test parameters can usually be set in a narrow range, and the installation of the measuring devices is difficult to solve, their placement is not adapted to the research task, but rather to the possibilities. On the other hand, the equipment I have created allows scientific examinations, the test parameters can be set on it in a wide range, the placement of the measuring devices can be adjusted specifically to the research purpose, while in the case of operating equipment it is often not possible.

2.1.1 *Physical model of a multi-source heat pump*

The essence of my dissertation is to examine the possibilities and effects of connecting several heat sources. This includes the possibility to adjust the parameters during the measurements and to reproduce the results within the applicability limits.

For the reasons mentioned in the previous chapters, of course, I did not perform the measurements for a year, but in some well-defined operating conditions. For the other operating conditions, I determine the results by calculation with the knowledge of the already known weather conditions or those previously modeled by others (Kayaci, 2018). This required the construction of an experimental facility that met the following requirements:

- It has at least two evaporators, at least one of which utilizes the heat content of the outside air
- Evaporators are suitable for parallel operation
- Their power ratio is freely adjustable
- The condenser side is a refrigerant-water heat exchanger

- Water inlet and outlet temperatures can be set and measured
- The effective power absorbed by the compressor can be measured
- Temperatures and pressures can be measured on the suction and discharge side of the compressor
- At least temperatures can be measured on the refrigerant inlet and outlet sides of the heat exchangers

The equipment obtained by my conversion meets the listed requirements, the connection of which is shown in Fig. 2.1. Figure illustrates:

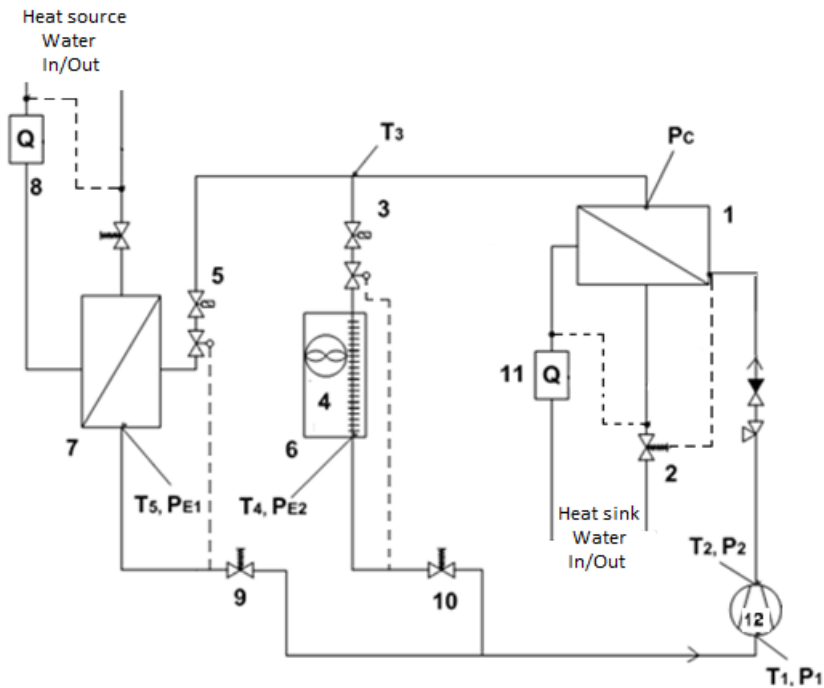

2.1. Refrigeration circuitry and components of the experimental equipment

1-condenser, 2-condensing pressure regulator, 3,5-solenoid valve, 4-electric heating filaments, 6-air heat source evaporator, 7-water heat source evaporator, 8-evaporator heat meter, 9,10-evaporator pressure regulator, 11-condenser side heat quantity meter, 12-piston compressor

After the appropriate modification of the experimental equipment, I performed several test measurements, based on the experience of which I made further corrections. The realized device is shown in Figure 2.2:

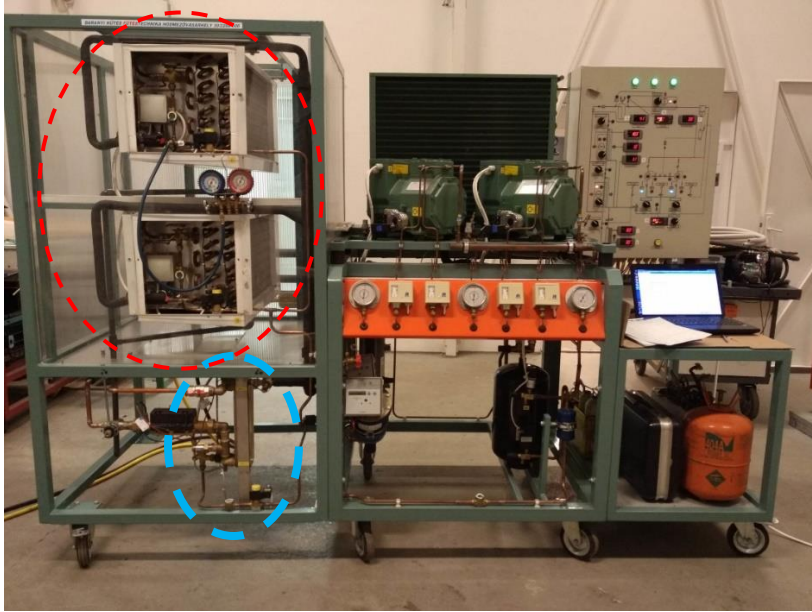

2.2. The implemented physical model

Fig. 2.2 shows a detail in red of the air chamber surrounding the air heat source evaporator. I made the temperature of this chamber adjustable with the help of electric heating inserts and a PID-type temperature controller. The water heat source is completely independent of this (detail marked in blue), the two do not interact from the heat source side. I took the water coming to the evaporator from the mains with cold water on one branch and domestic hot water on the other branch. By changing the ratio of the two, I was able to set the temperature and volume flow of the water used as the heat source, which characteristics I was able to check with the help of the electronic heat meter (8). The setting range was limited from below by the soil temperature, so I could not work stably in summer with temperatures below 20°C . Nevertheless, by changing the volume flow, I was able to set the evaporation temperature much lower. The used water was discharged into the sewer network during the experiments. In the case of a real system, of course, I would not choose this solution, but would prefer to use a soil collector, which does not require the extraction of water, only the circulation of the medium.

I used an alternating reciprocating compressor in the equipment, which is no longer common in this power range, as scroll or reciprocating compressors are most often used for the task. In the course of my work, I did not study the possibilities of power control, so even though the speed control of the Bitzer

alternating piston compressors I used can be solved with the help of a frequency converter, I did not take advantage of the possibilities of this. Thus, I was somewhat “wrong”, as the speed control always results in more favorable conditions in the evaporator for the temperature of the heat source and the refrigerant. The process is not reversible in the case of the equipment I examined, since the goal of performing the cooling task was only on the real evaporator side, I did not aim to examine the equipment that satisfies the cooling and heating task by reversing the process. I made a number of modifications to the equipment, the most significant of which I describe.

The condenser is designed to be suitable for measurement purposes and accordingly has refrigerant side pressure measurement points that are not available on commercially available types. The built-in condensing pressure regulator is also connected to this point, so it is suitable for setting and maintaining the exact value of the condensing pressure. I have minimized the water-side volume of the heat exchanger, so after a short time, the equipment is operating at a stable condensing pressure. This was confirmed during the test measurements, it took only 40... 60 seconds to reach the stationary condensing pressure, and the values were maintained without oscillation.

I made the heat output of the condenser and the water evaporator measurable on the water side using heat meters, as this was not possible in the original design of the equipment. This required modifying the route of several water and refrigerant lines that were part of the equipment, which I did myself. The resolution of the Siemens instruments originally used was not correct, so I replaced them with other types of equipment, which required further modifications due to the different connection size of the devices. The type of heat meters used permanently is described in the summary table of the instruments. The stability, accuracy, but especially the resolution of the new measuring instruments make them suitable for accurate measurements.

The equipment was basically for illustrative purposes, so despite having countless measurement locations on it, I had to change some of it. This mainly means measuring the temperatures of T5 and T6. I solved the problem by re-wiring two existing temperature sensors, so the measurements were made at these two locations with the same probe and instrument as the others. The aforementioned Bourdon tube manometers can be connected to the pressure measuring points via so-called schreder valves. I measured the evaporation pressure of the air heat source evaporator in this way, the electronic instrument used to measure the condensation pressure did not require intervention. The instruments used are described in detail in the following sections.

2.1.2 Equipment used for the defrost cycle test

In order to perform this task, it is absolutely necessary to know the time course of the temperatures reached at the characteristic points of the cooling circuit, as well as the intake and exhaust air temperatures play an important role. Correct, comparable measurements can only be made under laboratory conditions, where numerous interfering effects can be eliminated and the critical weather conditions in which the equipment is most sensitive to icing can be reproduced.

In order to carry out the planned tests, I had to develop a suitable device, the outline of which is shown in Figure 2.3. Figure shows. The heat pump tested was a split air conditioner with a nominal power of 2.5 kW, the outdoor unit of which was placed in a well-insulated chamber. The heat extracted from the chamber was covered to a lesser extent by the heat flow entering the boundary structures, but a very large part was introduced in the form of hidden heat with the water vapor produced in the steam generator connected to the chamber. With this procedure, the highest possible humidity in space is achieved, which at the same time ensures the highest degree of frosting in the case of the tested evaporator. The indoor temperature can be kept almost constant by changing the switching cycle time of the steam generator and by using air mixing fans. I performed temperature measurements at a total of 24 points, as well as the electricity consumption and the amount of condensate generated per cycle.

The outdoor unit was installed in a cooling chamber, which also has fans, so the air distribution in the tight space proved to be very even, the vertical temperature difference was not more than 1 ° C. The airtightness of the chamber is adequate, as the 2 holes with a 30 mm price gauge, through which the electrical and refrigerant lines run, are sealed. Thus, from a steam engineering point of view, the system is almost perfectly isolated to the outside world.

From a thermal engineering point of view, heat flows into the chamber from the outside to the heating of the air conditioner, which reduces the required heating output. The determination of this heat flux was performed experimentally, and its results and the conclusions that can be drawn are described later.

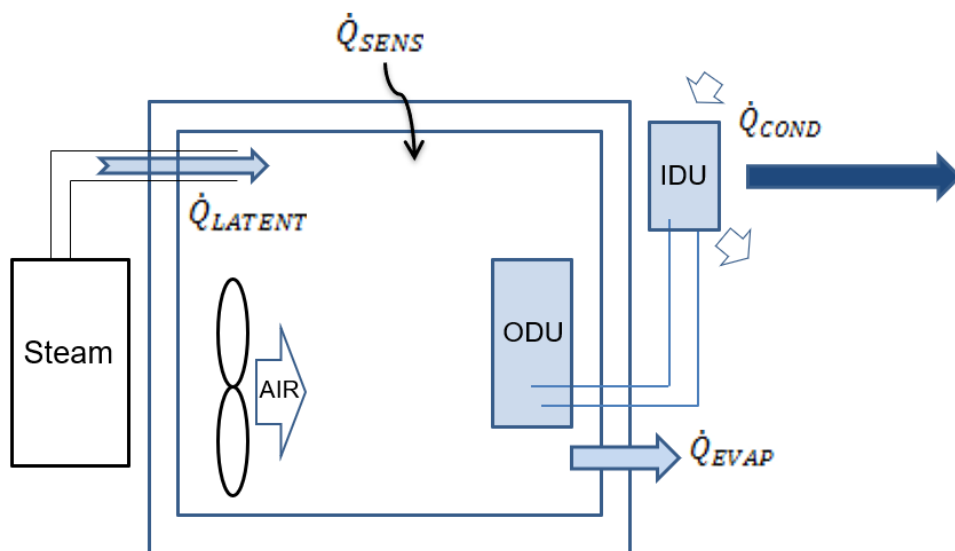

2.3. Schematic diagram of the measuring device

For the application of different refrigerants, I built new refrigerant connection points on the tested equipment, through which it was possible to drain the refrigerant, vacuum the system and load the new refrigerant, and I was also able to perform pressure measurements for control purposes. Instruments used in the measurements

As before, I describe the instruments and measuring systems used for my measurements in two groups. Due to the different nature of the two measurement tasks, the measurement systems are also different. In the study of defrost cycles, the evaluation of transients was very important because I had to determine the beginning and end of the defrost cycle during these short periods. This is very important because the length of the defrost cycles significantly affects the average performance available during periods of critical outside temperature. At the same time, in the case of the two heat source heat pumps, the opposite situation developed, where my goal was always to stabilize a certain operating state, and I recorded the data in this state. This was due to the fact that, here strictly, I was trying to compare certain operating conditions rather than to determine certain unknown cycle times.

2.1.3 Instrumentation of multi-source heat pumps

In this case, I measured certain cooling circuit characteristics in a stabilized operating state, so no machine data recording was required. Measurement of

instantaneous power values are very important for thermal power measurement tasks (condenser and water heat source evaporator). In the case of the heat measuring instruments I use, the power values can be read with a resolution of 0.001 kW at 20 s intervals, even though the original function of the instruments was not to measure the instantaneous power.

Nevertheless, the heat meter I used was able to display the current temperature and volume flow of the water flowing through it, thus significantly expanding the number of parameters that can be registered and evaluated.

Temperature measurements were performed with electronic thermometers and PTC probes, and pressure measurements were performed with Class 1 precision Bourdon tube manometers and an electronic instrument with a Honeywell pressure transmitter. For these, the resolution and settling time were not as critical as for heat meters.

2.1.4 Instrumentation of the equipment used to test the defrost cycle

To study the defrost cycles, it was necessary to analyze the transients and determine the time elapsed between them. Accordingly, I used machine data recording here. For my measurements I used the so-called IMRe - Intelligent Measurement System (Hermanucz et. Al. 2019), which has the huge advantage that it transmits the measured values to a server immediately. The data can also be displayed online via the Internet, but can also be exported retrospectively in .csv format. The data were recorded at 10s intervals, and in each case I used an on-line display for the duration of the measurement, so that I could observe the unfolding of one defrost cycle.

I attached the sensors to the copper tubes inside the device, shielded them from external influences with self-adhesive aluminum tape for proper heat conduction, and then with closed-cell tube insulation. I have documented the location and identifiers of the sensors, which already appear with a textual explanation during the evaluation. Where possible, I placed the measuring devices near the equipment's own sensors.

For energy evaluation, it is necessary to know exactly the volume flow of air distributed by the indoor unit. Although the manufacturer provides data for this, previous experience has shown that these are not always accurate. Therefore, I made my own measurements. On the intake side, I measured the air flow rate at 8 measuring points with heat wire and impeller air velocity meters. The measurement was performed for all fan stages (5 pcs) and in

cooling and heating mode. I have found that the volume flow delivered is different between the two modes.

2.2 Applied measurement settings

In the following sections, I describe the methods used in the measurements.

2.2.1 Settings for dual heat source heat pump

During my measurements with the physical model of the two heat source heat pumps, I used the evaporators with air and water heat source in parallel connection on the refrigerant side. The amount of refrigerant flowing into each evaporator is given in 2.1. I set it with the evaporation pressure control valves marked in detail 9.10, so I could change the performance of the two evaporators as desired. The calculation of the resulting power ratio is presented in Section 2.3.2. This will be an important parameter in comparing the measured and modeled operating conditions.

Unless otherwise indicated, the condensing pressure control valve was set so that the condensing temperature of the refrigerant was almost constant at 36 °C. I chose this value because it allows the production of flow heating water with a temperature of at least 30°C, taking into account the standard temperature difference of 5...6K. In the case of surface heating, a lower water temperature is rarely required, and in the case of a higher condensing temperature - with increasing condensing pressure - the heat pump can only deliver lower power. This means that lower performances must be taken into account on the heat removal side as well, so we would be mistaken for safety in the possible sizing of the evaporators. I used evaporation pressure regulators in two ways:

In a self-regulating system: at this time the pressure regulators were in the end position and I only changed the evaporation temperature of the air heat source by setting the air temperature of the experimental chamber between 35...5°C. I kept the temperature of the water heat source at a nearly constant 10°C, considering that water from a properly sized soil heat source can be expected to have a similar temperature. I did not affect the amount of refrigerant entering the evaporators, thus the performance of the evaporators. Measurements were performed with 14 different settings and three replicates.

In a controlled system: I then set different evaporation pressures with the help of pressure regulators, thus controlling the performance of the two heat sources operating in parallel. Measurements were performed with 14 different settings and three replicates. I have chosen the setting range so that

the evaporation pressures are suitable for the critical weather conditions in Hungary. Accordingly, the pressure of the evaporators was set in the equilibrium temperature range of 0...12°C, which means a constant temperature of + 5...25°C for the air heat source and a constant temperature of 20°C for the water heat source.

2.2.2 Settings used to test defrost cycles

With the help of the measuring system, the outside temperature can be set within very wide limits, however, I always kept the relative humidity at the maximum value. The setting value that best suited the purpose of my studies was determined during preliminary experiments. As a result, I decided to examine the outdoor temperature of -5°C in detail, and this will also be shown in the figures. My decision was based on the fact that at this temperature the air can still hold significant humidity, but it is sure to freeze on the surface of the heat exchanger. Of course, I performed several measurements in the range of -10...+2°C, but I only evaluated the length of the defrost cycles. Preliminary measurements show that this does not necessarily occur above + 2°C or only for a very long time, despite the fact that the evaporation temperature of the medium is slightly below freezing.

The settings were the same for all three refrigerants I tested, R410a, R32, and R290. The effect of the three refrigerants on the defrost cycles was investigated primarily, so I did not evaluate them from an energy point of view. The energy evaluation was performed only for the factory R32 gas charge.

The selected chamber temperature of -5°C and relative humidity of 100% are the same as the weather environment considered critical for the evaporation of the evaporator in Hungary, and proved to be a well-adjustable and reproducible setting during the test measurements. I always kept the desired condenser side temperature at a maximum value so that the control of the equipment's own power could not interfere with the measurement.

2.3 Evaluation methods

I describe the evaluation methods and calculations used in my research in the following chapters.

2.3.1 Defining characteristics that are difficult to measure

In the case of the two heat source heat pumps, I did not have the possibility to measure certain cooling circuit parameters, so I developed a calculation

method to determine them, which is described below. Measuring the power taken from the air heat source is difficult because the air velocity and temperature should be measured at several points on the evaporator face, the air density should be calculated, and many measurement data should be evaluated in one operating condition. The effect of moisture condensing from the air would also be very difficult to take into account, as indicated by the examination of the defrost cycles, and this operating condition should be avoided with this test equipment. Of course, in the case of a real system, condensation occurs, but it only creates more favorable conditions than the one I examined, but I would complicate the measurement procedure disproportionately, so I determined the power taken from the air heat source by calculation.

2.3.2 Power ratio of evaporators of multi-source heat pumps

The power ratio of the evaporators of the two heat source heat pumps is an important parameter for the comparability of the results. I calculated this with the following relation, which practically shows the share of water heat source, and 1-x the share of air heat source:

$$k = \frac{\dot{Q}_{water}}{\dot{Q}_{water} + \dot{Q}_{air}}, \quad (2.1)$$

where

\dot{Q}_{water} the heat input of the water heat source evaporator, and

\dot{Q}_{air} calculated power of the air source heat evaporator.

2.3.3 Data recording, remote access

The data preprocessed by the intelligent metering system used to measure the defrost cycles is transmitted to the server center via the WiFi network at the set 10 sec metering intervals. The data recorded here can be assigned and viewed to graphs, ie various display solutions, on the Internet search page. However, it is also possible to export the data to .csv format, which allows evaluation in excel. Inaccuracies resulting from data recording could be eliminated. The 20-second refresh cycle of the heat meters helped to maintain the same intervals. The data for both measurement systems were collected and organized into excel spreadsheets.

2.3.4 *Mathematical background for data evaluation*

I present the evaluation of the measurement data with the help of diagrams, and the measured and calculated characteristics can also be found in the appendix. I fitted a trend line to the data series, I gave the degree of fit (R2) and the root of the mean square error (RMSE) in the relevant cases, and I was able to draw useful conclusions from them.

$$RMSE = \sqrt{\sum_{i=1}^n \frac{(\hat{y}_i - y_i)^2}{n}}, \quad (2.2)$$

where

\hat{y}_i the value determined by the function,

y_i the value determined by the measurement,

n the number of the observations.

The RMSE value shows how much the measurement results “scatter” around the fitted curve, expressed in the same dimension as the measured characteristic.

2.3.5 *Determination of defrost cycle times*

An important part of my work was to get to know the defrost cycle time of air source heat pumps, which requires a clear definition of what I consider to be a defrost period and an operating period. Given that the exact definition of the defrost cycle is not known, I will briefly describe the procedure I have used:

I consider the defrost cycle to be the period during which the power delivered by the capacitor is not positive.

For a significant part of the defrost period, the useful power is zero, but heat removal is also experienced. Therefore, it is not trivial from which point in time I calculate the defrost period and from which time the operating period. The most important results of the series of measurements are the length of the cycle, the use of energy, and the examination of the agreement of the measured data with the results of previous research.

3 RESULTS

In this chapter, I present the results of the measurements performed with the two measurement systems, as well as the results of the software calculations and the developed mathematical models. The results for the two measurement systems are described in separate chapters.

3.1 Experimental results of a multi-source heat pump system

In this chapter I describe the results achieved with the experimental equipment of the two heat source heat pumps and the possibilities of their utilization.

3.1.1 Test of simultaneous, parallel operation of an air and water heat source

The first series of experiments I performed was to examine the power factor available with heat sources connected in parallel. For comparison, I also measured the power factor obtained using 100% water and 100% air heat sources at the same evaporation temperatures. Given that the temperature of the soil (and thus of the water used as a medium) changes only slightly during the year, I set this to a constant 10 ° C for comparison and the temperature of the air chamber to + 6... 18 ° C, and I represented a power factor belonging to. The results are shown in Figure 3.1. Figure shows.

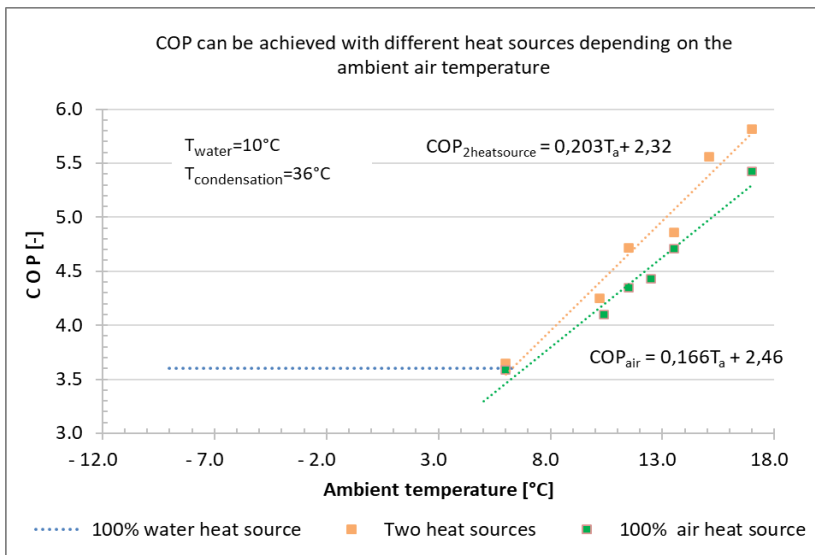

3.1. COP can be achieved with different heat sources depending on the ambient air temperature

When using the two heat sources, I used the self-regulating setting method described in Section 2.2, when testing the 100% water and 100% air heat sources, I switched off the complementary heat source, and the use of a choke was not justified.

It can be observed that at outdoor temperatures higher than + 6°C, the use of two heat sources results in the most favorable performance factor, while the use of a 100% water heat source has proven to be economical. The slope of the $COP_{2\text{heatsources}}$ correlation describing the COP of the two heat sources exceeds the slope of the COP_{air} correlation obtained when using a 100% air heat source, so the COP achievable with the two heat sources is higher in the range of outdoor air temperatures higher than + 6°C. The RMSE value for the correlation describing the behavior of the two heat source systems was 0.133, while for the correlation belonging to the 100% air heat source it was 0.098. The results can be generalized by considering the standard temperature steps ($\Delta T = 5\text{K}$ for water and $\Delta T = 10\text{K}$ for air heat source evaporators). The results confirmed my preliminary assumption that a higher power factor can be achieved using two heat sources than using a water or air heat source alone.

3.1.2 Adjusting the power ratio of evaporators operating in parallel with a pressure control valve

In this case, my goal was to adjust the performance of each evaporator by changing the evaporation pressures using a pressure control valve. The condensing pressure was kept constant at 36°C, because no lower value is required for heating use, and the air heat source temperature was set in the range + 10... 20°C and 16 different settings were tested in triplicate, 20°C water source temperature next to. Evaporation temperatures, of course, were in the range of -2... +7°C.

A 3.2. Figure 5 shows the available power factor as a function of the power ratio of the water and air heat source evaporators connected in parallel. In the case of $k = 0$ only the air heat source, while in the case of $k = 1$ only the water heat source operated. I fitted a quadratic polynomial to the measurement points with an equation of $COP = -3.107k^2 + 3.227k + 4.469$ with a fit of 0.74 and RMSE = 0.162.

Figure 3.2 shows the available power factor as a function of the power ratio of the water and air heat source evaporators connected in parallel. In the case of $k = 0$ only the air heat source, while in the case of $k = 1$ only the water heat source operated. I fitted a quadratic polynomial to the measurement

points with an equation of $\text{COP} = -3.107k^2 + 3.227k + 4.469$ with a fit of 0.74 and RMSE = 0.162.

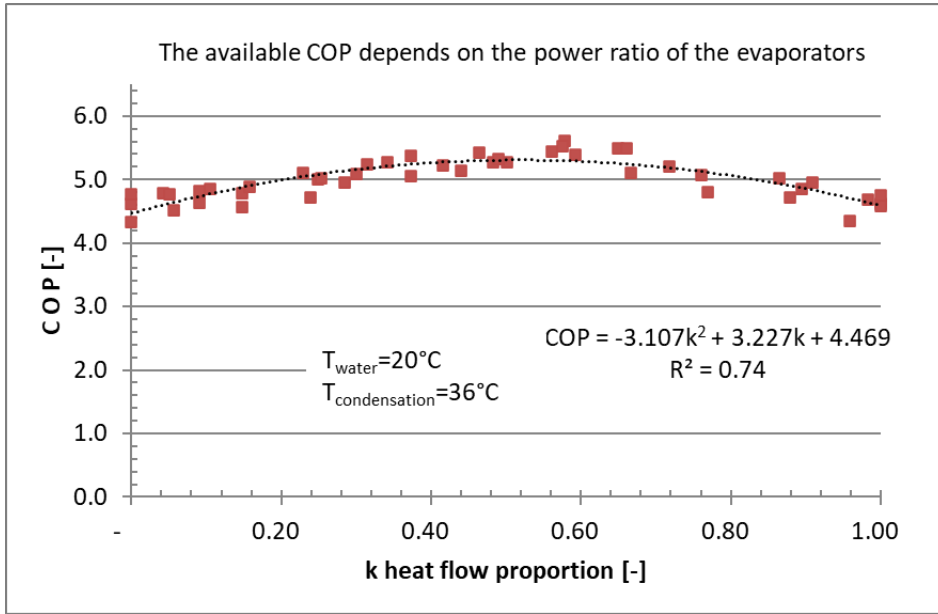

3.2. The available COP as a function of the power ratio of the evaporators

It can be stated that even with such a simple control method, the reduction of the power factor compared to the maximum will not be greater than 10%. With the help of this, I can determine in the modeling how if the power of the air heat source is reduced by artificial choking in order to avoid icing, how the power factor will develop. The same situation occurs if e.g. taking into account the capacitive properties of the soil, we want to use the air source in the autumn despite the fact that we can do this with a slightly worse power factor, but we can avoid the early cooling of the soil. Thus, we will have a higher soil temperature during the lower outdoor temperature period.

3.1.3 Power ratio of evaporators operating in parallel without regulation

In this case, my goal was to adjust the performance of each evaporator by changing the temperature of the heat sources without any other external intervention. The condensation pressure was kept nearly constant at 36°C and 16 different settings were tested in triplicate. The temperature of the air heat source was set between $35\dots5^\circ\text{C}$ and the water heat source was kept constant at 10°C .

In this case, the so-called external pressure-compensated thermostatic expansion valves used in the system are responsible for the distribution of the refrigerant. These control the overheating that is set and kept constant during each measurement by changing the amount of refrigerant added. In the event of unfavorable conditions in one of the evaporators, less and less refrigerant is allowed in the evaporator to achieve the set superheat. In extreme cases (eg $k < 0.1$ or $k > 0.8$) the capacity of the evaporator can be reduced to 10% of the nominal value or even the evaporator can be completely shut down.

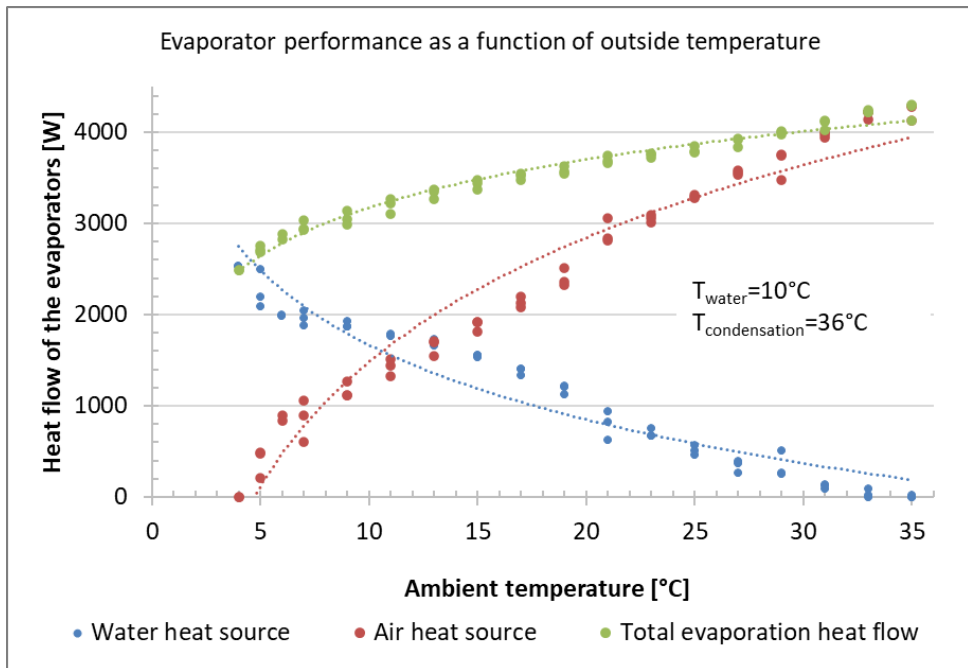

3.3. Evaporator power and power ratio as a function of outdoor temperature

The figure shows how the change in air temperature affects the total performance of the two evaporators. The temperature of the air heat source during the measurement has an effect only on the evaporator utilizing the air heat source, and thus on the entire cooling circuit, but it has no effect on the evaporator utilizing the water heat source.

It can be seen that at temperatures below $+10^{\circ}\text{C}$ the performance of the air heat source decreases rapidly and becomes practically zero below $+5^{\circ}\text{C}$, while of course the performance of the water heat source is maximized. The green curve shows all the abstract heat output. The reduced heat output with

the outside temperature is due to the decreasing evaporation temperature, which of course also reduces the useful heating capacity and COP of the heat pump. The results show that it is possible to assemble a system where the performance of the air heat source automatically decreases in the critical temperature range $-5\dots +5^{\circ}\text{C}$ for the defrost cycles, the role of the water heat source is taken over. A power ratio can be assigned to each outdoor temperature, which does not depend on the design of the unit, the nature of the functions remains similar for other heat exchanger sizes and capacities.

Examining the practical utilization of the experimental result, it can be said that this avoids the freezing of the air evaporator, and even if freezing does occur, it does not adversely affect the operation, as the iced heat exchanger switches off practically automatically and then reappears when the outside temperature rises. This avoids a significant reduction in operating time, as I explained in Section 3.2.2. Figure 3.4 shows the change in the power ratio “k” as a function of the outside air temperature.

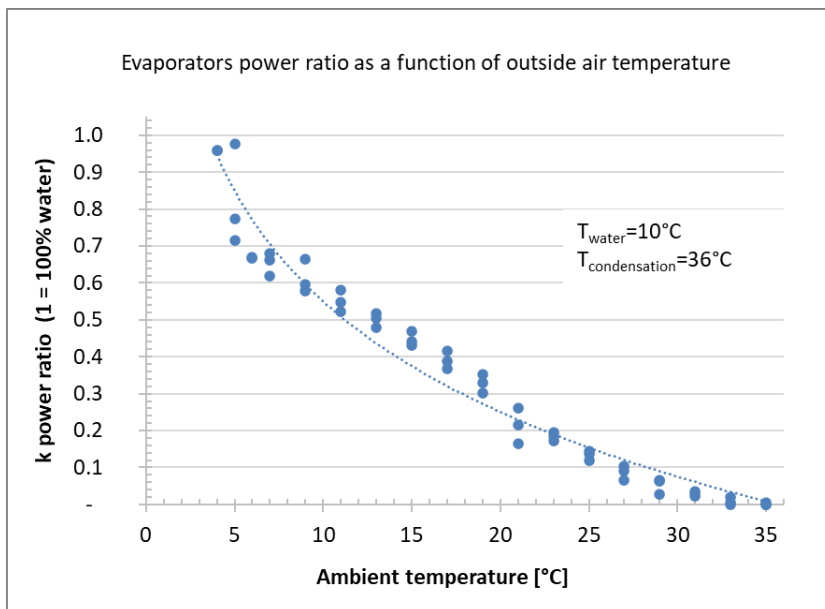

3.4. The power ratio of the evaporators as a function of the outside air temperature

It can be observed in the figure that the characteristic curve is difficult to fit to the measuring points in the range $k = 0\dots 1$, because on the one hand a very sudden change occurs in the range $1 > k > 0.8$, and on the other hand the slope of the curve decreases. However, a simple and relatively wide-ranging relationship that describes the change in power ratio as a function of outdoor

temperature would be very useful for modeling the system and performing seasonal calculations. Therefore, by narrowing the examined range to $0.1 < k < 0.8$, the results are shown in Figure 3.5.

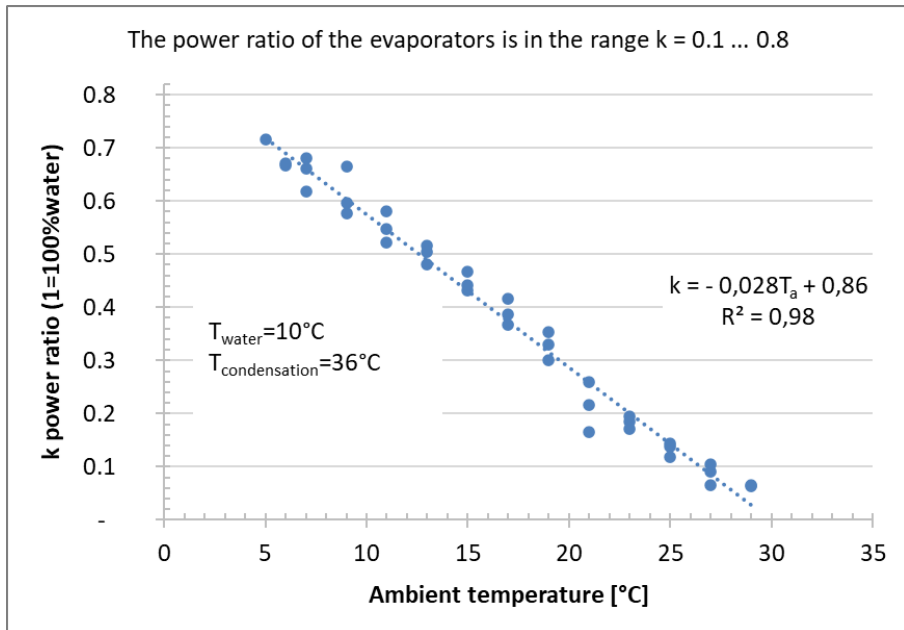

3.5. The power ratio of the evaporators in the range $k = 0.1 \dots 0.8$

It can be seen that even in a very simple relation with $R^2 = 0.98$ and $RMSE = 0.03$, the power ratio of the evaporators as a function of the outside temperature can be described if the control of the system is entrusted to the thermostatic expansion valves with external pressure equalization.

3.1.4 Comparison of regulated and self-adjusting systems

The purpose of comparing the two measurement layouts is to find a parameter along which the power factor achievable with the two layouts will be comparable. In my research I found that in the case of a self-aligning system the power factor can be well described by the arithmetic mean of the evaporation temperatures or the weighted average of the power ratios, while in the case of the controlled system the arithmetic mean cannot be used instead. Thus, choosing the weighted evaporation pressure as a parameter, I found that the power factor of the two systems shows a very good agreement in the evaporation temperature range of $0 \dots +6^{\circ}\text{C}$ with a water heat source of 20°C and a condensing temperature of 36°C . Figure shows. The RMSE value here was 0.25.

Consequently, the power-weighted average of the evaporation temperatures is suitable for modeling a non-existent parallel-connected evaporator system as a single evaporator system in conventional refrigeration modeling software, as long as the input parameters, primarily evaporation pressure and evaporator performance, can be determined.

Practically useful result, because I created the possibility to model the heat pump system with two heat sources, ie. with two evaporators connected in parallel, with the help of two separate systems with one evaporator, and to validate the model results with any set evaporation pressures.

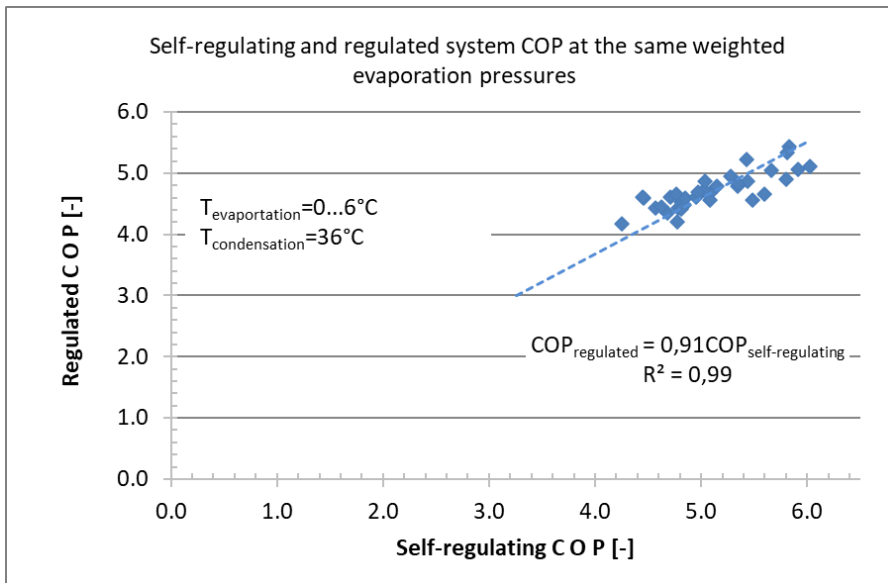

3.6. Self-regulating and regulated system COP at the same weighted evaporation pressure

3.1.5 Features modeled in software and their comparison with the measurement results

The purpose of this series of tests is to provide a procedure for modeling two heat sources connected in parallel using familiar software. In these software, it is not possible to set up a cooling circuit of this design directly, so a measurement-validated procedure is required to perform the task using existing software.

I used Solkane 7.0 software for modeling. The two heat sources were modeled as two separate cycles, the common parameter being the power-weighted average of the evaporation temperatures. The input parameters of

the model were the evaporation and condensation temperatures and the evaporator performance, which were determined by measurement and calculation according to Section 2.3.2. As an important result for me, I got the COP, which I also determined with the experimental equipment. The tests were mainly performed at a constant condensation temperature (here 44°C) with 12 different evaporation settings in the range of -2... +9.5°C, which resulted in 10 different power ratios in the range $k = 0.1 \dots 0.8$. The high condensing temperature used is specifically intended for energy recovery for heating. In this case, it is not necessarily a problem that this degrades the COP, because the goal is to perform the heating task, the extra energy intake is utilized here. The results resp. their conformity is determined in 3.7. Figure shows.

It can be seen that a simple correlation with a good fit and a minimum value of $RMSE = 0.068$ was found. This allows me to specify the mentioned values to be used as the input data of the software, with the help of which I get a performance factor that is in good agreement with the measured data:

$$Q_{evap} = \dot{Q}_{water} + \dot{Q}_{air} , \text{ and} \quad (3.1)$$

$$P_{evap} = 1,087 \cdot (k \cdot P_{E6} + (1 - k) \cdot P_{E5}) . \quad (3.2)$$

The described relationships are specifically for data entry into Solkane 7.0 software, so I have indicated the evaporator performance differently than usual, and no evaporator mass flow is required. Examining the relationship between the measured and calculated characteristics, I found that the mathematical relationship between the two can be written in a simple form, as shown in Figure 3.8.

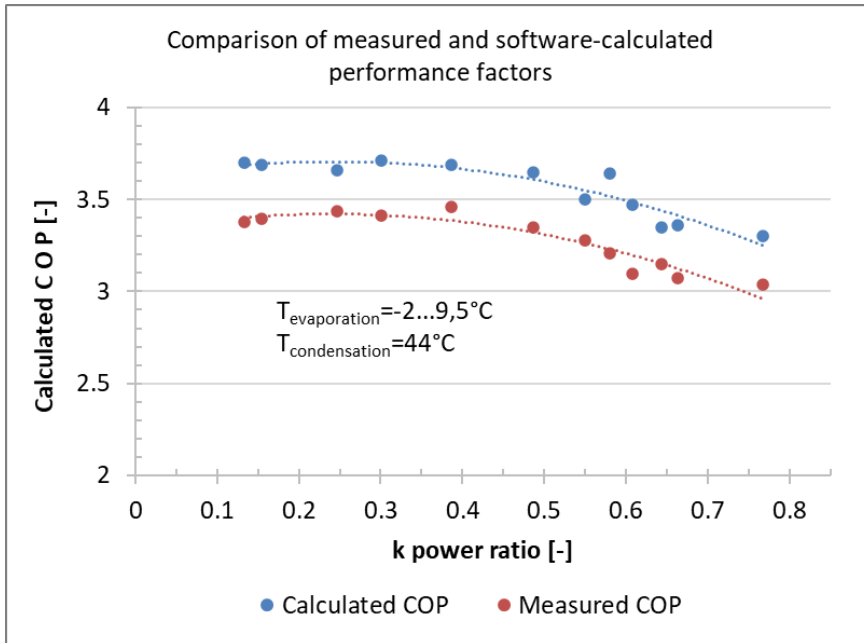

3.7. Comparison of measured and calculated characteristics for software model validation

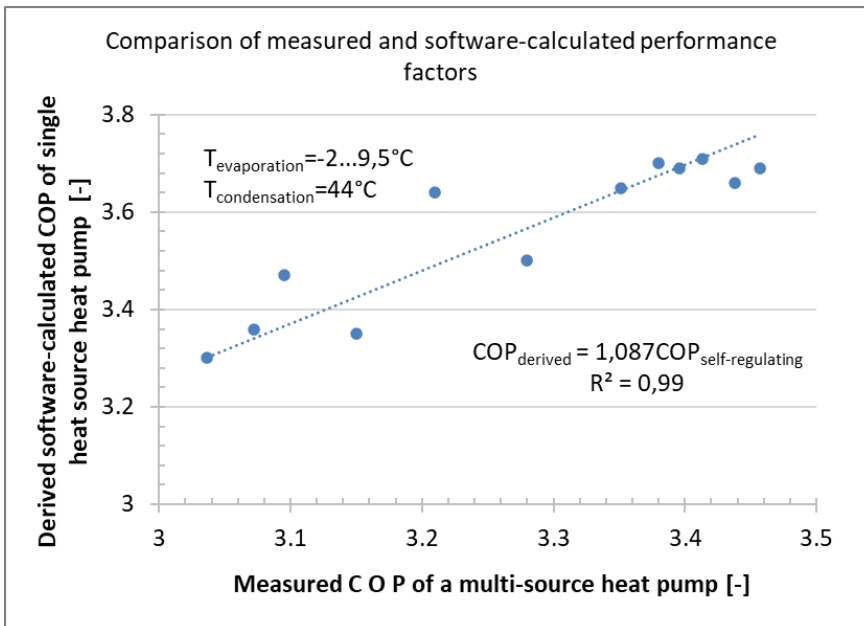

3.8. Comparison of measured and calculated performance factors for software model validation

3.2 Defrost cycle measurement results

To model the entire system, I needed to determine the extent of the seasonal power outage caused by the defrost cycles, which I determined using the measurements described below.

3.2.1 *Evaluation of the measurement results of the defrost cycle*

Given that the exact definition of the defrost cycle is not known, I will briefly describe the procedure I have used: I consider the defrost cycle to be the period between the two zero-power moments of the compressor. During the period, heat is also removed from the heated space. Within the defrost cycle (section “C”, 8 minutes 26 seconds), I calculated the amount of electrical power absorbed by the compressor (596 W) and the COP value determined separately for the average evaporation temperature of the same section for the entire defrost cycle. The heat removal is used to cool the air passing through the gravity of the indoor unit heat exchanger or the out-of-service fan.

During the analysis of the data, I made sure that in the sections B-C-D, up to the “H” point, the heat dissipation at the indoor unit is paused and heat is removed for some time. The results show a low COP, but the power delivered during operation is maximally satisfactory. A very important lesson from the series of measurements is that the net power measured with the defrost cycles is 32% lower than what the unit can deliver during operation. This can be partly explained by the length and period time of the defrost cycles (no useful power 25% of the time), and partly by the length of the defrost and load periods reducing the average useful power. The electrical power absorbed during defrost cycles is much lower than during operation. Calculation and measurement have shown that the rate of heat removal is not critical. The value of the performance factor was in good agreement with the catalog and literature data. With my measurements I was able to prove that the amount of heat absorbed from the air in the form of latent heat can exceed 10% of the amount of heat absorbed from all environments.

Measurements to determine the length of the defrost cycles were performed on two devices in the power range of 2...4kW in the outdoor temperature range of -10 and + 1°C with at least 4 settings and 3 repetitions per refrigerant. The purpose of the studies was not to show the difference between the refrigerants, but to demonstrate that the trend is generally true regardless of the properties of the refrigerant. At the same time, I consider it important from an environmental point of view to study the behavior of

R290 refrigerant in the refrigerant circuit, as it has significant environmental advantages over R410a and its COP does not lag behind it in the case of properly sized refrigerant circuits. The test for R32 refrigerant was justified by the fact that many equipment is supplied with this refrigerant today. The results are shown in Figure 4.14.

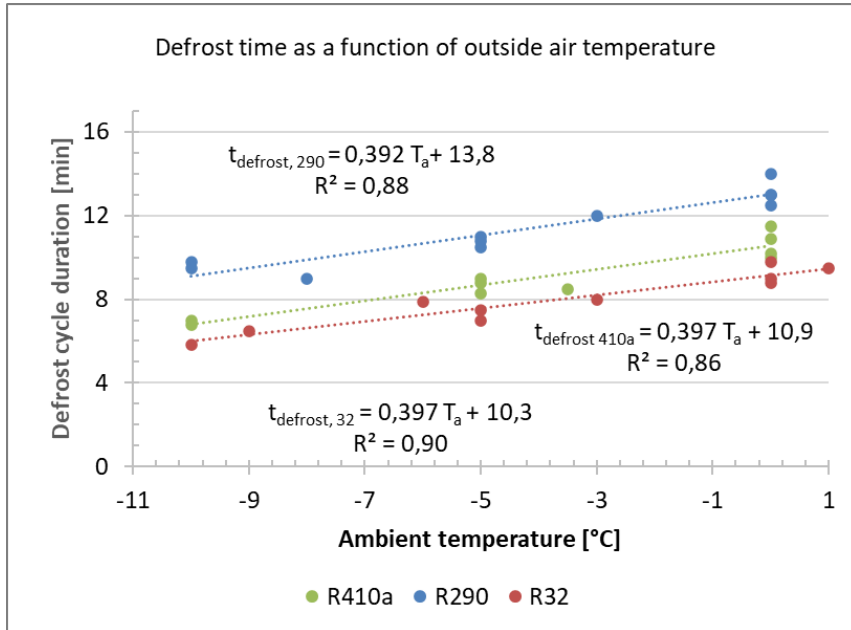

3.9. Variation of the defrost time as a function of the outside temperature for two refrigerants

It can be observed that I obtained an increasing thawing time as the outside temperature increased. This can be explained by the phenomenon that the structure of the frost layer changes at low temperatures, so condensation and freezing of smaller amounts of water already significantly impairs heat transfer. Thus, at lower outside temperatures, less condensate must be melted, which can be achieved with less energy investment. In other words, with increasing outside temperature, more condensate must freeze to reduce the same heat transfer, so more energy is needed in one cycle, resulting in a longer defrost cycle. Given that I did not find any such findings during the detailed literature review, I consider the above to be a new scientific result. My suggestion was also confirmed by the examination of the amount of condensate belonging to each cycle, because in the case of each refrigerant I was able to collect an increasing amount of condensate as the outside temperature increased.

I controlled the temperature of the test chamber with the amount of introduced steam, my goal was to keep the relative humidity of the chamber at a maximum value, which is close to the real environmental parameters in the critical temperature range critical for defrost cycles. As the temperature of the chamber increases, so does the amount of heat extracted, and thus the amount of steam introduced per unit time. However, this is not a problem for testing the length of the defrost cycles, as the unit always starts defrosting under the same conditions, i.e. when the difference between the refrigerant leaving the evaporator and the ambient temperature increases. Thus, the length of the cycle is not affected by the degree of wetting, only the period time, which was accordingly evaluated only for the critical temperatures outside my own measurements. For the annual modeling, I used the results of other researchers, which also take into account the change in ambient air humidity.

Defrost cycles are practically non-existent at temperatures above +2°C. Mathematically, this would mean that the plotted curves would drop sharply to 0 here, the physical content of which would be difficult to identify. The explanation for this phenomenon lies in the defrosting strategy of the heat pump: defrosting always starts when the temperature of the evaporator outlet line falls below the intake air temperature by a certain value, see 2.7. as shown in Figure. As this is an artificial intervention that affects the time elapsed between the defrost cycles, it is possible that a unit jump transition may occur in the behavior of the defrost cycles. This is accompanied by a change in period time. Based on the equations shown in the diagram, I conclude that there is a linear relationship between the defrost cycle time and the outside air temperature, which is

$$t_{defrost} = L \cdot T_a + E \tag{3.3}$$

describes a general relation, where the constants L and E for the refrigerants I tested are described in Section 3.2. according to the table.

3.2. Table The constants I determined for each refrigerant

Refrigerant	L	E	R ²	RMSE
R32	0.397	10.3	0.9	0.97
R290	0.392	10.9	0.86	0.99
R410a	0.397	13.8	0.88	0.55

R^2 characterizes the fit of the function, the value of RMSE shows the scatter of the measured values relative to the fitted function. These constants can be used to calculate, among other things, the reduction in annual operating time caused by defrost cycles, which can be avoided by using a dual heat source arrangement.

3.2.2 *A way to reduce annual power outages by using an additional heat source*

Once I have found a computational correlation to determine the defrost time as a function of outdoor temperature, and a correlation between defrost cycles for optimal duration is known from previous literature, I can use weather data to determine the downtime during the heating season. Of course, this also results in a reduction in performance, the extent of which I can also determine.

The time required for defrosting was calculated for the R410a refrigerant, which is common today:

$$t_{defrost,410} = L_{410} \cdot T_a + E_{410} \quad (3.4)$$

where:

T_a the ambient temperature [$^{\circ}\text{C}$].

This relationship is suitable for determining the total defrost cycle time as a function of outside temperature and relative humidity. The complete cycle is the sum of the optimum operating time and the defrost time:

$$t_{cycle} = t_{opt} + t_{defrost} \cdot \quad (3.5)$$

The power outage I have defined can be interpreted during the hours of the year when the outside temperature is below $+2^{\circ}\text{C}$. For these periods I determined the values of t_{opt} and t_{leolv} separately, from which the rate of reduction of the operating time became calculated:

$$t_{break} = \sum t_{defrost} \text{ , and} \quad (3.6)$$

$$X = \frac{t_{break}}{t_{heating}} \cdot \quad (3.7)$$

In the case of average conditions in Hungary, $t_{heating} = 4000 \text{ h}$, which results in $X = 4.4\%$, $t_{reduction} = 177 \text{ hours}$, which can be avoided by using two heat sources in parallel, so that it is not necessary to scale the soil heat exchanger to serve the entire system all year round.

This fact points out that it is not self-evident to judge the extra cost of installing a heat pump with a heat source to be examined. Of course, the installation cost of two heat sources is higher than that of one heat source, but it must be taken into account that the two heat sources cover the heat demand together during the year, so even in terms of their maximum capacity, they do not have to be scaled alone throughout the year. This is mainly due to the soil heat source, as the soil temperature remains higher during the critical period due to the lower annual utilization, so there is no need for such a large soil collector.

The evaporator, which utilizes the air heat source, is sufficient to be scaled to an outside temperature of $+5^{\circ}\text{C}$, during which time it stops automatically. A further reduction in size can be achieved by scaling the air heat exchanger taking into account the power ratio relationship I have outlined, as its power is already significantly reduced below $+10^{\circ}\text{C}$. Another possibility of utilizing the two heat source arrangements is conceivable in technological processes where cooling and heating are also installed, but basically they would be equipped with separate equipment.

3.3 New scientific results

1. *Higher COP can be achieved with two heat source heat pumps than with one heat source.*

Based on my measurement results, I conclude that by using two heat sources simultaneously, in parallel, without control - keeping the water heat source temperature constant at 10 ° C, setting the air heat source temperature in the range between +6...+ 17°C at a constant condensation temperature of 36°C taking into account the 10K temperature step of the evaporators - for air temperatures above +6°C, the slope of the function describing the COP of the two heat source systems is higher than for a system using only air heat sources, and for air temperatures below +6°C the only-water heat source COP is higher.

2. *If two heat sources are used in parallel, the optimum power ratio of the evaporators can be set by means of a choke.*

Based on my measurements on an heat pump with an evaporative pressure control valve and two heat sources, I conclude that if I adjust the power ratio of the two heat sources using chokes, the power factor will be maximum at +20°C water and +10...+20°C air heat source temperature. which, in the range of evaporation temperatures between -2...+7°C and a constant condensation temperature of 36°C, is described by a quadratic relation, the maximum COP reduction of which, in the range $k = 0... 1$, is not exceeds 10%, allowing easy and fast automation with low energy loss.

3. *In case of simultaneous, parallel, unregulated use of air and water heat source, frosting of the evaporator using the air heat source can be avoided.*

Based on my measurements on a heat pump with a thermostatic expansion valve with external pressure compensation without additional control, I find that - between a constant temperature of 10°C water and +5...+35°C in 2°C air heat source and 36°C condensing in case of temperature - the output of the air heat source drops to zero below +5°C air temperature, thus avoiding frostbite of

the evaporator, which avoids a 4.4% loss of operating time in one heating season.

4. *COP can be described as a function of the evaporation-weighted average evaporation pressure for both throttled and self-regulating systems.*

Based on my measurements performed in the range of 0...+6°C evaporation temperature critical for the frosting of air heat source evaporators - +20°C water heat source and 36°C condensing temperature using choke power ratio control and self-regulation system - I find that with choke between the COP values of the regulated and the self - adjusting system

$$\text{COP}_{\text{regulated}} = 0.91\text{COP}_{\text{self-regulating}}$$

there is a correlation between $R^2 = 0.99$ and $\text{RMSE}=0.25$ when I examine it as a function of the evaporation pressure weighted by the performance of the evaporators, thus allowing the results of the software model to be validated at any settings.

5. *A heat pump with two evaporators connected in parallel can be modeled as an evaporator using evaporator pressure weighted according to the power ratio of the evaporators.*

Using two heat sources simultaneously, in a choke-controlled manner - with an evaporation temperature of -2... + 9.5 ° C and a constant condensation temperature of 44 ° C in the power ratio range $k = 0.1... 0.8$ - based on measured and modeled results $R^2 = 0.99$ and $\text{RMSE} = 0.25$ - I determined the

$$Q_{\text{evap}} = \dot{Q}_{\text{water}} + \dot{Q}_{\text{air}}, \text{ and the}$$

$$P_{\text{evap}} = 1.09 \cdot (k \cdot P_{E6} + (1 - k) \cdot P_{E5})$$

relationships that allow a model of a heat pump with two evaporators connected in parallel to be modeled with software for modeling a heat pump with only one evaporator.

6. *The cycle time for defrosting an air heat source shows a linear relationship with air temperature.*

Based on my measurements on air-to-air heat pumps in the 2... 4kW useful heating power range - with three types of refrigerant charge in the air source range of -10... 0 ° C at a constant relative humidity of

85% and a constant condenser side temperature of 23°C - I conclude that within the test range, the time required to defrost the evaporator while maintaining the factory defrost regulations can be described as

$$t_{defrost} = L \cdot T_a + E$$

where L and E are constants specific to the given refrigerant.

7. *The power ratio of the evaporators can be described as a function of the outside temperature.*

Based on my measurements on a heat pump with an externally pressurized thermostatic expansion valve without additional control, I conclude that - between a constant water temperature of 10°C and + 5... +30°C in 2°C steps, the heat source and 36 ° C condensing for temperature - the power ratio of the evaporators in the range $0.1 < k < 0.8$ can be described as

$$k = -0.028 \cdot T_a + 0.86$$

by $R^2 = 0.98$ and $RMSE = 0.03$, which makes it possible to accurately scale the evaporator utilizing the air heat source.

4 SUMMARY

In the initial phase of my research, I conducted a literature search on several subfields, which, in addition to processing the scientific results of the utilization of several heat sources so far, covered the possibilities of refrigerant change, defrosting methods and defining defrost cycles. In addition to a number of useful information, I also found shortcomings in the literature search, for example, the possibilities of using several heat sources in parallel were not or were not examined in the way I suggested. Also, one of the disadvantages of the air heat source, the defrost cycle and its energy, with special regard to the relationship with the outside temperature, has not been studied in detail. I did not find any example of describing the evaporators operating in parallel in the cooling circuit modeling software, a problem which I managed to solve as a result of my work.

In the course of my work, I have found that it is possible and reasonable to supplement a conventional air source heat pump with another heat source, such as a water-mediated medium evaporator that utilizes ground heat. The system is also suitable for the simultaneous service of technological cooling and heat demand, or even for the utilization of waste heat. I also found the rate of power loss due to defrost cycles when using conventional air source heat pumps. By using the system I have proposed, which has not been studied before by others, it is possible to eliminate this decrease in performance.

An important finding of the research is that the evaporation temperature of the air heat source decreases according to the weather conditions, however, the extent of this significantly exceeds the decrease of the evaporation temperature of the water heat source. There are two main reasons for this: on the one hand, heat from the ground is available at a nearly constant temperature throughout the year, and on the other hand, the heat transfer coefficient of the refrigerant-water heat exchanger depends significantly on the evaporator load (increasing load improves heat transfer). its factor is primarily determined by the air side, so it can be considered nearly constant. As a result, the evaporation temperature of the air side decreases significantly, while that of the water side decreases only slightly with increasing load, with the self-regulating nature of the power ratio of the two sides always reaching the optimum value.

The use of external pressure-compensated thermostatic expansion valves is responsible for the automatic nature of the system, so that the behavior of any similarly designed system will be similar, and the results can be

generalized in this way. It is important to emphasize that the use of two heat sources does not mean the installation of twice as many heat exchanger surfaces, as it is possible to serve the needs with smaller heat exchanger surfaces compared to a single heat source system in full load operating conditions (domestic hot water production in summer and heating at low outside temperatures).

I also did not come across a similar design to the equipment created to study the defrost cycles during the literature search. This subtask, although at first sight it may not seem to be organically related to the topic indicated in the title of the dissertation, has had many results in the course of the research. Such was the knowledge of the length of the defrost cycles as a function of the outside temperature and the refrigerant used, which yielded unexpected results. The results also contributed to the determination of the annual power outage, which can also be considered as filling a gap, as no information can be found in the publications or in the data sheets of the heat pumps. The measurements were performed on several heat pump types with different performances with several repetitions.

5 MOST IMPORTANT PUBLICATIONS RELATED TO THE THESIS

Referred articles in foreign languages

1. Hermanucz, P., Géczi, G., Barótfi, I. (2022): Energy efficient solution in the brewing process using a dual-source heat pump. Thermal Science, DOI: TSCI210901026H
2. Székely, L., Kicsiny, R., Hermanucz, P., Géczi, G. (2021): Explicit analytical solution of a differential equation model for solar heating systems. Solar Energy, 222, pp. 219-229. (0038-092X)

Referred articles in Hungarian language

3. Hermanucz, P., Géczi, G., Barótfi, I. (2019): Hűtőközeg váltás hőszivattyúra gyakorolt hatásának mérési lehetőségei. Jelenkori Társadalmi És Gazdasági Folyamatok, 14, 1, pp. 71-76.
4. Hermanucz, P., Géczi, G., Barótfi, I. (2021) Levegő hőforrású hőszivattyú leolvasztási módszerei. Magyar Épületgépészet, 70, 12, pp. 1-5.
5. Hermanucz, P., Benécs, J., Barótfi, I. (2022): Levegő hőforrású hőszivattyú leolvasztási ciklusának energetikai vizsgálata. Magyar Épületgépészet, 71, 1, pp. 7-12.