

DOCTORAL (PhD) DISSERTATION

DOI: 10.54598/000050

MOHANAD ALI KAREEM

KAPOSVÁR

2020

**SZENT ISTVÁN UNIVERSITY-KAPOSVÁR CAMPUS
FACULTY OF MANAGEMENT AND ORGANIZATIONAL
SCIENCES**

Head of Doctoral School

Prof. Dr. IMRE FERTŐ DSc

Supervisor

Dr. CECÍLIA MEZEI

Associate Professor

**THE MEDIATING ROLE OF DYNAMIC CAPABILITIES
ON THE RELATIONSHIP BETWEEN HUMAN
RESOURCE DEVELOPMENT AND ORGANIZATIONAL
EFFECTIVENESS**

Written by

MOHANAD ALI KAREEM

DOI: 10.54598/000050

KAPOSVÁR

2020

Contents

CHAPTER ONE	7
INTRODUCTION	
1.1. Study background	8
1.2. Scope and focus of the study	10
1.3. Problem statement	10
1.4. Research questions	11
1.5. Objectives of the study	12
1.6. Model of the Study	12
1.7. Dissertation structure	13
1.8. Definition of Terms	14
CHAPTER TWO	17
RESEARCH METHODOLOGY	
2.1. Overview	18
2.2. Research design	18
2.3. Operationalization of Variables	19
2.4. Description of the study area	22
2.5. Population and Sampling procedure	24
2.6. Instrumentation development	25
2.7. Data collection procedure	27
2.8. Data analysis procedure	28
2.9. Validity and reliability measurement	28
2.10. Structural equation modeling.....	29
CHAPTER THREE	31
THE IMPACT OF HUMAN RESOURCE DEVELOPMENT ON ORGANIZATIONAL EFFECTIVENESS	
3.1. Introduction	32
3.2. Literature review and hypotheses development	33

3.3. Research Methodology	45
3.4. Results	49
3.5. Discussion and conclusions	54
CHAPTER FOUR	57
THE IMPACT OF DYNAMIC CAPABILITIES ON ORGANIZATIONAL EFFECTIVENESS	
4.1. Introduction	58
4.2. Literature review and hypothesizes development	59
4.3. Research Methodology	68
4.4. Results	71
4.5. Discussion and conclusions	75
CHAPTER FIVE	79
MEDIATING ROLE OF DYNAMIC CAPABILITIES ON THE RELATIONSHIP BETWEEN HUMAN RESOURCE DEVELOPMENT AND ORGANIZATIONAL EFFECTIVENESS	
5.1. Introduction	80
5.2. Literature review and hypotheses development	82
5.3. Research Methodology	88
5.4. Results	92
5.5. Discussion and conclusions	98
CHAPTER SIX.....	102
DISCUSSION AND CONCLUSIONS	
6.1. Overall discussion and conclusions	103
6.2. Theoretical implications	104
6.3. Managerial implications	105
6.4. Limitations and future research	106
THE NEW SCIENTIFIC RESULTS	108
SUMMARY	110
ACKNOWLEDGMENT	113

REFERENCES	115
PUBLICATIONS RELATED TO THE TOPIC OF THE DISSERTATION	140
CURRICULUM VITAE	144
APPENDIX	146

Content of figures

Figure 1. A proposed research model	13
Figure 2. locations of state universities on the Iraq’s map	23
Figure 3. Academic staff in Iraqi universities	24
Figure 4. A proposed research model of HRD and OE	45
Figure 5. The SEM model analysis of HRD and OE	53
Figure 6. A proposed research model of DC and OE	68
Figure 7. The SEM model analysis DC and OE	75
Figure.8 Conceptual model of HRD, DC, and OE	88
Figure 9. The SEM model analysis of HRD, DC, and OE	98

Content of tables

Table 1. the study variables in regard to the sections of the questionnaire, sources, and number of items	26
Table 2. The demographic data of the respondents	46
Table 3. the study measures in regard to the sections of the questionnaire, sources, and Cronbach’s alpha	48
Table 4. Descriptive and correlation results	50
Table 5. Constructs evaluation	51
Table 6. Discriminant validity of the constructs	52

Table 7. Result of hypothesis analysis	53
Table 8. the study measures in regard to the sections of the questionnaire, sources, and Cronbach's alpha	70
Table 9. Descriptive and correlation results	71
Table 10. Constructs evaluation	73
Table 11. Discriminant validity of the constructs	74
Table 12. Result of hypothesis analysis	75
Table 13. The study measures in regard to the variables, sources, and Cronbach's alpha	91
Table 14. Descriptive and correlation results	92
Table 15. Index of confirmatory factor analysis.....	93
Table 16. Constructs evaluation.....	94
Table 17. Discriminant validity of the constructs.....	96
Table 18. Results of direct effects.....	97
Table 19. Results of mediating effect.....	97

CHAPTER – ONE

INTRODUCTION

1.1. Study background

I have chosen this research theme due to the fundamental characteristics of the business environment in which organizations work in today's world are knowledge-based competition and rapidly changing markets. To survive in such an environment, the organizations must possess a capable human resource that enables them to keep facing these challenges and compete to achieve excellence. As result, the concept of human resource development (HRD) has emerged as a strategy to improve employee's competences in turn to enhance organizational effectiveness (Gberevbie,2012; Potnuru and Sahoo, 2016).

The higher educational organizations surely do not operate in a vacuum. They operate in national and international environments, they strive to integrate resources and coordinate strategies to meet challenges and shifts in the environments and take advantage of opportunities (Yuan et al. 2016).

The most valuable human resource in higher education organizations are lecturers and researchers who comprehend the strategic and operational objectives, who possesses human capabilities and knowledge. Without staff having a convenient qualification, educational and research experience and the right attitude, higher educational organizations cannot operate effectively.

I argue that human resources development is one of the most important tasks faced by contemporary organizations, under the conditions of scarcity and its indicators such as (talent development, training and development, organizational development and, career development) are increasing day by day. The recent studies (Chang, 2011; Blanco and Botella, 2017; Otoo and Mishra 2018) have emphasized the distinctive role of the human resource in the work of organizations, which requires serious attention if they want continuing success and excellence. Also, several researchers (Nilsson and Ellstrom 2012; Schuler and Jackson, 2014; Alagaraja et al. 2015) have confirmed that human resource development practices have a significant

positive impact on organizational effectiveness. Moreover, this study argues that in rapidly changing environments it is imperative that organizations to develop capabilities to meet and cope with the environmental turbulence what are so-called dynamic capabilities in order to achieve superior organizational effectiveness.

The dynamic capabilities (DC) has emerged as an attempt to untangle the complex problem of organizational performance in today's dynamic environment (Olovsson and Lundström, 2010). Dynamic capabilities are an organization's ability to integrate, build and reconfigure internal and external resource to address environmental changes (Teece et al.,1997).In term of the relationship between human resource development (HRD) and dynamic capabilities, many researchers (Wang et al. 2012; Wilhelm et al.,2015; and Helfat et al.,2007) have established that HRD plays a key role in supporting the creation and maintenance of dynamic capabilities in order to keep pace with the firm's environment.

Leih and Teece, (2016) argue that if higher education organizations want to maximize organizational effectiveness, they must continuously align their internal and external capabilities to the challenges and/or opportunities offered by the environments. These efforts require universities to improve employees' competencies through HRD practices that may contribute, in aggregate to cope with environmental changes.

Despite this progress, there is still a lack in the literature about an understanding of the mediating mechanisms of dynamic capabilities on the relationship between HRD practices and organizational effectiveness. Based on the knowledge of the author there were no studies investigated alternative relationships. Consequently, this study tries to address this gap by proposing an empirical model that demonstrates dynamic capabilities constructs i.e. sensing capabilities, learning capabilities and reconfirmation capabilities mediate the relationship between HRD constructs i.e. talent development,

training and development, organizational development, and career development and organizational effectiveness.

Overall, two important motivations fuel this study. First, theoretically, this study provides a research model for empirical literature in the field of human resource development, dynamic capabilities, and organizational effectiveness. Second, empirically this study provides practical implications for universities management. Also, it provides significant insight and demonstrates a good understanding of HRD practices, dynamic capabilities and organizational effectiveness in the selected Iraqi public universities context. The findings of this study have the potential to help decision-makers to develop their HRD practices and adopt dynamic capabilities mechanisms to improve organizational effectiveness.

1.2. Scope and focus of the study

The scope of the thesis is within the fields of strategic management and human resources. More specifically three key focuses fuel this study. Firstly, the central focus is the universities' specific HRD practices – which contribute to organizational effectiveness. Secondly, the study also pays attention to the universities' integrating, building, and reconfiguring resources and strategies, which may develop solid dynamic capabilities that allow them to meet environments change. Thirdly, the study explores the integration between HRD practices and dynamic capabilities that is might improve the universities' effectiveness. The study took place in the top ten public universities of Iraq. Higher education plays a vital role and function in the advancement of competitiveness and efficiency of the nation's economy. The higher education sector is worthy of such a research effort due to the social and economic benefits it delivers to developing countries in general and Iraq in particular.

1.3. Problem statement

The global competition and the rapid growth of the knowledge economy in a highly changeable environment has encouraged the organizations to develop a paradigm to understand how to sustain their competitiveness and achieve superior organizational effectiveness. The aforementioned literature have highlighted that HRD practices have a significant positive impact on organizational effectiveness. But, with the rapid shifts in business environments, HRD is often not the best strategy to enhance organizational effectiveness (Teece et al., 1997 and Aminu and Mahmood, 2015). Therefore, this study argues that in such a dynamic environment HRD practices have the potential to influence organizational effectiveness through the mechanism of dynamic capabilities. The explanation of the linkage between HRD, dynamic capabilities and organizational effectiveness HRD is still unexplored.

Moreover, the serious attention and efficient and effective use of human resource development at the level of Iraqi educational organizations is still below the required level, due to the current circumstances in the country, and the reflection on the entire educational process. Thus, the Iraqi educational organizations need to understand the role of HRD practices in achieving organizational effectiveness by means of dynamic capabilities. Due to the lack of empirical research in this issue, this study proposes a set of research questions as mentioned below.

1.4. Questions of the study

The following research questions will be addressed in order to guide the acquisition of data required to satisfy the statement of the problem:

1. To what extent does human resource development influence dynamic capabilities?
2. To what extent does human resource development influence organizational effectiveness?

3. To what extent do dynamic capabilities influence organizational effectiveness?

4. To what extent do the dynamic capabilities mediate the relationship between human resource organizational effectiveness?

1.5. Objectives of the study

The primary objective of this study is to examine the impact of human resource development on organizational effectiveness and explores the mediating role of dynamic capabilities on the relationship between human resource development and organizational effectiveness in selected Iraqi public universities context. More specifically the study sought:

1. To assess the theoretical significance of human resource development, dynamic capabilities and organizational effectiveness which are considered critical factors in the success of the organizations.

2. To find an empirical model, which can test the relationship between human resource development and organizational effectiveness.

3. To test the proposed model empirically and investigate the relationship between dynamic capabilities and organizational effectiveness.

4. To identify and empirically assess the effect of HRD on organizational effectiveness by means of mediating effect of dynamic capabilities.

1.6. Model of the Study

Demonstrates the hypothesized research model which proposes that HRD constructs i.e. talent development, training and development, organizational development, and career development are positively related to organizational effectiveness constructs i.e. goal approach, system resource approach, and competing values approach. Likewise, HRD constructs i.e. talent development, training and development, organizational development, and career

development are positively related to dynamic capabilities. Also, the dynamic capabilities construct i.e. sensing capabilities, learning capabilities and reconfiguring capabilities positively related to organizational effectiveness constructs. Lastly, the dynamic capabilities construct i.e. sensing capabilities, learning capabilities and reconfiguring capabilities mediate the relationship between HRD constructs and organizational effectiveness constructs.

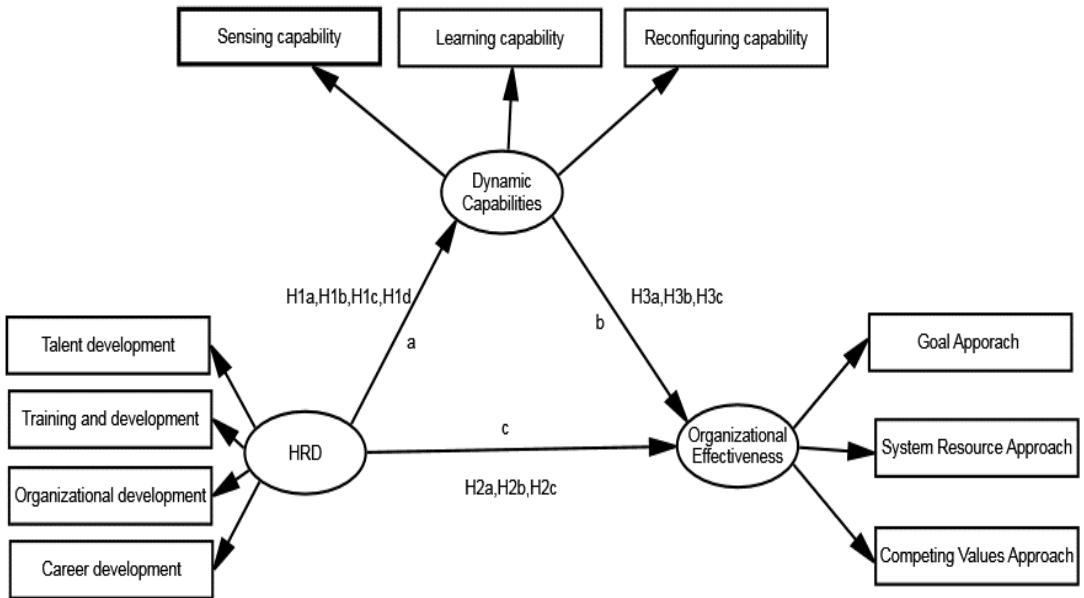

Figure 1. A proposed research model

Source: researcher own construction

1.7. Dissertation structure

To address the research questions and objectives, I conducted six chapters, which were combined to constitute this dissertation. Moreover, this dissertation applies type B of dissertation structure. I conducted three empirical studies to test the proposed model empirically and investigate the relationships among human resource development, dynamic capabilities, and organizational effectiveness as shows in chapters three, four and, five.

Chapter one describes a brief overview of the background of the study, defined the research problem, states the research questions, research objectives, and the research hypotheses, shows the research model, presents a brief of the research methodology, and lastly, the definition of terms.

Chapter two discusses the methodology adopted for the study. This chapter is divided into eight sections. Section one describes the research design. Section two shows the operationalization of variables. Section three presents the description of the study area. Section four shows the population and sampling procedure. Section five describes the instrumentation development. Section six presents the data collection procedure. Section seven describes the data analysis procedure. Lastly, section eight presents the validity and reliability of the instrumentation.

In chapter three I examined the direct effect of human resource development constructs i.e. talent development, training and development, organizational development, and career development on organizational effectiveness.

In chapter four I investigated the direct effect of dynamic capabilities constructs i.e. sensing capability, learning capability, and reconfiguration capability on organizational effectiveness. In chapter five I explored the mediating role of dynamic capabilities in the relationship between human resource development and organizational effectiveness. Chapter six presents an overall dissection and conclusion regarding the several studies building this dissertation thesis and provides new scientific results and the theoretical and practical implications.

1.8. Definition of Terms

1. Human resource development (HRD) is a systematic process of educating and acquiring new skills, knowledge, and abilities of individual, group and organizations through application of talent development, training and development, career development, and organizational development initiatives.

2. Talent development refers to a systematic process of attraction, identification, development, and retention of those individuals with high potential who are of particular value to an organization.
3. Training is a process of increasing an employee's ability to perform through learning, changing the employee's attitude and increasing their skills and knowledge in order in order to enable organization to achieve its strategic objectives.
4. Organizational development is a systematic process of transferring the behavioral science to develop the planned progress, improve, and emphasis on strategies, structures, and organizational processes for improvement of organizational effectiveness
5. Career development is a lifelong process of identifying the individual interests, competencies, activities, and job assignments required to develop individual employee skills for future needs of the organization.
6. Dynamic capabilities are the organization 's ability to integrate, build, and reconfigure internal and external competencies to address rapidly changing environments.
7. Sensing capability is the organization's ability to recognize shifts in the environment that could impact the organization's operations.
8. Learning capability is the organization's ability to create internal knowledge, to acquire external knowledge, and to assimilate internal and external knowledge through knowledge sharing.
9. Reconfiguring capability is the organization's ability to create new capabilities, reconfigure assets and organizational structures to address the markets and technology changes.

10. Organizational effectiveness is the ability of an organization to achieve its goals, stability, productivity of the organization, adapt to the changing business environment, workforce development, and optimal utilization of resources.

CHAPTER – TWO
RESEARCH METHODOLOGY

2.1. Overview

The purpose of this study is to empirically examine the impact of human resource development on organizational effectiveness and investigates the mediating role of dynamic capabilities between the relationship of human resource development and organizational effectiveness in the sample of Iraqi universities. This study is employed a quantitative research methodology to address the proposed research questions and hypothesizes.

This chapter describes a detailed discussion of the methodology adopted for the study. This chapter is divided into nine sections. Section one describes research questions. Section two presents research hypotheses. Section three discuss the research methods. Section four shows the research design. Section five describes the population and sample selection. Section six presents instrumentation development. Section seven describes data collection procedures. Section eight discuss the data analysis techniques. Lastly, section nine presents the validity and reliability of the instrumentation.

2.2. Research design

This research used a quantitative methodology. A quantitative methodology is suitable to use in hypotheses testing of the relationship between independent and dependent variables (Sekaran and Bougie, 2013). The purpose of this quantitative method is to verify the research hypotheses. According to Harvard University (2014), a quantitative research approach is appropriate when specific hypotheses are tested, concepts are defined as distinct variables, procedures are standard, and analysis occurs using statistics, tables, and charts. This study meets these criteria. This study uses a primary data to address the purpose and objectives of the study. This study adopted the survey method to collect the primary data. (Creswell, 2003) states that in general, researchers and scholars adopt a quantitative research often employ survey method because it is considered an economical and efficient method to gather

quantitative data concerned to a given population for the purpose of generalizing the result. Furthermore, HRD researchers such as (Hua, 2013; Tsang-Kai, 2010 and Potnuru and Sahoo,2016) mostly use a quantitative methodology often rely on data collected through surveys. Within the quantitative methodology data analysis usually occurs to test hypotheses using statistical methods.

2.3. Operationalization of Variables

2.3.1. Independent variable

In this study, the researcher designed one independent variable which is human resource development (HRD). In this study, HRD is considered as latent variable means not directly measured, expressed by a set of observable variables that serve as indicators. In the literatures and previous studies such as (Mafi,2000; Hassan,2007; Spirina,2015 and Potnuru and Sahoo,2016) were measured HRD in three indicators training and development, organizational development, and career development. According to (Tomé, 2011) in his study HRD measured in four indicators, which are training and development, organizational development, and career development and performance development. In this study, the independent variable of HRD was measured in four indicators or observable variables of talent development, training and development, organizational development, and career development. The talent development measures the attraction, identification, development, and retention of talented individuals. Training and development measure the effectiveness of training and development programs are implemented. Organizational development measures the extent to which, application and transfer of behavioral science knowledge to the planned progress, improvement, and reinforcement of the strategies, structures, and processes in order to improve organizational effectiveness. Career development measures

the extent to which, the process of identifying the individual interests, competencies, activities, and job assignments required to develop individual employee skills for future needs of the organization.

2.3.2. Dependent variable

The dependent variable for this study is organizational effectiveness. There are many and different approaches to measure the organizational effectiveness. The literature and scholars have developed varieties of models to indicate and measure the organizational effectiveness such as (Shah,2016) in his study proposed six indicators to measure the organizational effectiveness are: motivation, organizational commitment, organizational attachment, organizational innovation, consensus and job involvement. While (Kaur, 2013) proposes four indicators to measure the organizational effectiveness are production, efficiency, satisfaction, and organizational development. (Gold et al,2001) state the dimensions of organizational effectiveness include innovation, coordination, and rapid commercialization of new products.

Balduck and Buelens (2008) and Potnuru and Sahoo (2016) argue that organizational effectiveness can't be measured by a single approach only, as it is a multi-approach concept. In the literature, (Lee, 2006; Robbins, 2003; Wolfe and Putler, 2002; and Banat, 2002) there are four key approaches for measurement of organizational effectiveness: goal approach; system resource approach; strategic constituency approach; and competing values approach. For the purpose of this study, the researcher designed three approaches to measure the organizational effectiveness: first, goal approach measures the extent to which, the organization is effective in achieving its stated goals. Second, system resource approach measures the ability of organization to acquire necessary resources from the environments. Third, competing values approach measures the organization's ability to adaptation to the changing

business environment and emphasis on optimization of resources, stability, and flexibility.

2.3.3. Mediator Variable

A mediator variable also called “intervening or process variable” is the variable that mediates the relationship between the independent variable and the dependent variable (Kenny and Judd, 2014; Muller et al.2005). Moreover, when structural model is examined, the mediator variable is the most interesting part of that model where the independent variable first influences the mediator variable, and then the mediator influences the dependent variable (Namazi and Namazi, 2016). This study considered dynamic capabilities as the mediator variable. The literature and scholars have developed varieties of models to measure the dynamic capabilities such as (Teece et al.,1997 and Eisenhardt and Martin, 2000) developed three dimensions to measure the dynamic capabilities: learning capabilities, integration capabilities, and reconfiguration capabilities. (Nieves, 2014; Labanauske and Nedzinskas,2015,) determined the dynamic capabilities four measured dimensions: sensing capability, learning capability, integration capability, and coordinating capability.

In this study, the researcher determined the dynamic capabilities in three measured dimensions: sensing capability, learning capability, and reconfiguration capability. Sensing capability measures the organization’s ability to recognize shifts in the environment that could impact the organization’s business. Learning capability measures organization’s ability to create internal knowledge, to acquire external knowledge, and to assimilate internal and external knowledge through knowledge sharing. Reconfiguration capability measures organization’s ability to create new capabilities,

reconfigure assets and organizational structures to address the markets and technologies changes.

2.4. Description of the study area

Iraq has an inveterate intellectual history dating back to the ancient Mesopotamian civilizations. Also, during the early Arab-Islamic empires of the ninth century, Iraq had remarkable accomplishments. The Iraq's modern higher education sector dates back a century when a college of law was established in Baghdad in 1908. A number of other colleges and academies were established in the city between the 1920s and the 1950s, (Harb,2008).

The current situation, according to Ministry of Higher Education and Scientific Research (MHESR), Iraq's higher education system comprises 35 state universities: 378 colleges and 28 institutes and 66 private colleges and universities. In addition, Iraqi commission for computers and informatics and Iraqi committee for medical specialties. All of the institutions are supervised by the Ministry of Higher Education and Scientific Research in Iraq (Al-Essa, 2018). Figure 2 shows the locations of 35 state universities on the Iraq's map. Iraq presently consists of 19 governorates and at least two state universities in each governorate but, in the capital city (Baghdad) there are ten state universities as it shows in fig.2 below.

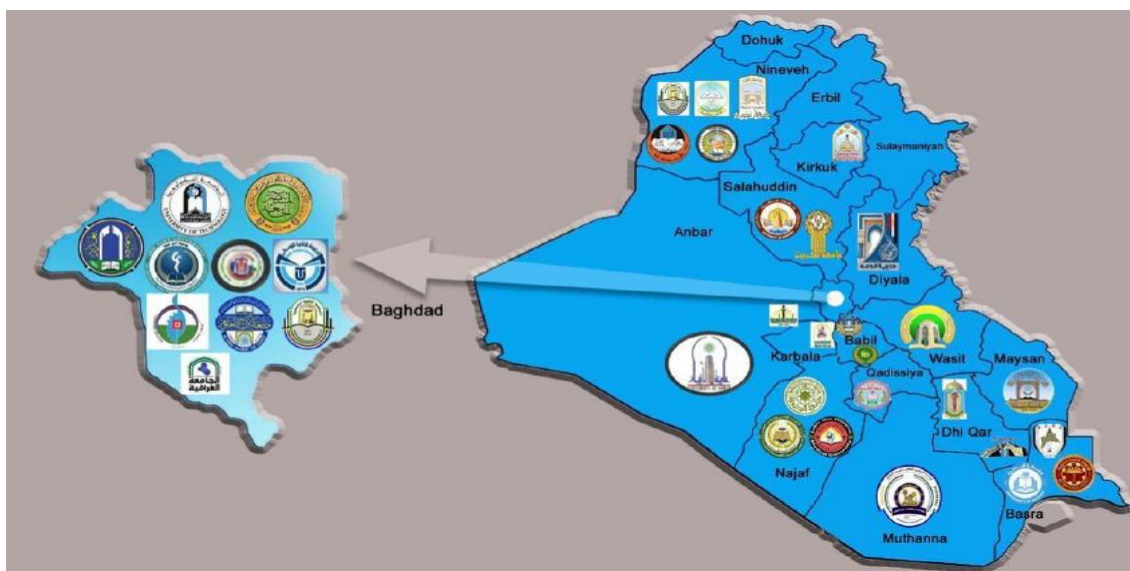

Figure 2. locations of state universities on the Iraq's map

Source: (Al-Essa, 2018)

According to (Al-Essa, 2018) the academic staff of Iraqi universities consist of Professors, assistant professors, lecturers, and assistant lecturers and their number reached are 46041. Out of the 46,041university teaching staff, 65% were males and 35% females. Figure (3) shows the number of academic staff in the Iraqi universities in the academic year between 2012\2013 -2016\2017. The total number of the academic staff in 2012\2013 was 39445 then it's increased to 46041 in 2016\2017. The master's degree is the minimum educational qualification for teaching in higher education. Faculty members with Ph.D. degree are more desirable because of their knowledge, skills, and capacity which have potential to graduate students and to advise them in their master's and Ph.D. theses, about one-third of faculty members lack a master's. 28% had Ph.D., 39% had master's degrees, and 33% had only a bachelor's degree. The higher education and scientific research ministry of Iraq play a key role in developing the academic staff in its universities. MHESR indicates that teaching staff need more attention because it is considered the core element in the education system, so the priority should be given to develop the teaching

staff, by providing them the necessary training and development programs to improve their knowledge, skills, and abilities. The universities and institutes ensure the freedom of research, publishing, and ownership rights, also encourage and enhance scientific output, and immunity and the freedom of expression and belief, to enhance the scientific and technical of the teacher's competences and provide appropriate and comfortable academic environment, to develop his achievements.

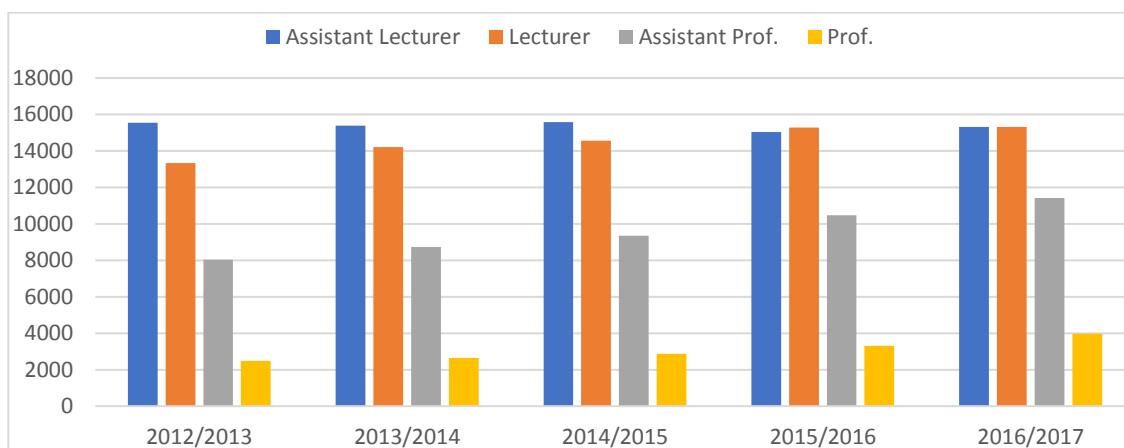

Figure 3. Academic staff in Iraqi universities Source: (Al-Essa, 2018)

2.5. Population and sampling procedure

Sekaran (2003) defines population as the object for study which consists of events, individuals, groups of people, institutions, to which we want to generalize the findings. The study took place in top ten Iraqi public universities (University of Babylon, University of Baghdad, Diyala University, University of Mosul, University of Basrah, Kufa University, Mustansiriyah University, University of Anbar, and Kerbala University) the population consisted of deans, heads of departments, faculty members and principals of the execution units of the selected Iraqi public universities which seems to provide a corresponding sample for conducting data collecting and analyzing. However, including the whole population in the study is often not practically reasonable

and uneconomical since it consists of a huge number of employees; therefore, a sample was selected from the total population to present as representatives. Sampling is the process of selecting a subset of the total population to include in the study to address the research objectives (Sekaran, 2003). There are two sampling methods: probability and non-probability sampling techniques. The study employed non-probability sampling based on purposive sampling method, which is appropriate for the scope and nature of the study. A purposive sample is one in which participant selection is based on meeting certain criteria of interest to ensure the most relevant information is obtained based on the population (Cooper and Schindler, 2011). According to (Sekaran and Bougie,2013) this sampling technique involves choosing participants that are well equipped with relevant information pertinent to the study focus. In this regard, the sample frame for this study included deans, heads of departments, faculty members and principals of the execution units of the selected Iraqi public universities were targeted to provide a corresponding sample for conducting data collecting and analyzing.

2.6. Instrumentation development

This study adopts a web-based survey for collecting data from the sample of the study. Online questionnaire was developed by Google-Forms tool. According to (Grohmann and Kauffeld (2013) questionnaire is often used while adapting survey method. The questionnaire was developed based on an extensive review of the literature related to topic of the study. The questionnaire comprises of three sections (see appendix). Section one collects participant and institutional background information of the respondents such name of the university, age, gender, position held, educational attainment, work experience, and organization size. Section two includes questions are designed to measure the variables of the study by using a comparative seven-point Likert-type scale ranging from 1-7, in which, 1 = strongly disagree, 7 =

strongly agree. Moreover, 20 items are designed to measure HRD constructs which are talent development, training and development, organizational development, and career development and 15 items designed to measure dynamic capabilities constructs which are learning capability, sensing capability, integrating capability and lastly, 12 items designed to measure measures the organizational effectiveness constructs which are goal approach, system resource approach, and competing values approach. In the third section of the questionnaire includes 10 concluding questions designed to measure descriptively the implementation of HRD in the selected Iraqi public universities.

The web-based questionnaires were distributed through e-mail designed to collect the relevant data from the selected public universities of Iraq totaling 10 universities including a number of deans, heads of departments, faculty members and principals of the execution units which seems to provide a corresponding sample for conducting data collecting and analyzing. Table (1) shows detailed information regarding the variables, sources, and number of the items as follows:

Table 1. the study variables in regard to the sections of the questionnaire, sources, and number of items

sections	Name of the variable	Source	Number of items
section one	participant and institutional background information	Researcher developed	9
Section two	Human resource development constructs: Talent development, training and development, organizational development and career development.	(Mahfoozi et al.,2018),(Asfaw et al.2015),(Sabarina,2015), (Parvaneh,2016),(Zadehaand Ghahremanib,2016),(Xueling,2017),(Wengand McElroy,2012)	20

	Dynamic capabilities constructs: Sensing capabilities Learning capabilities Reconfiguration capabilities	(Teece et al. ,1997) ,(Eisenhardt and Martin ,2000),(Nievesand Haller,2014)	15
	Organizational effectiveness constructs: Goal approach System resource approach Competing Values Approach	(Gold et al., 2001), (Rahman et al., 2013),(Banat,2002),(El Khair,2016)	12
Section three	Human resource development – concluding questions	Partly adapted from (Stephen,2016) and, (Singleton,2014), Some questions are developed by the researcher	10
Total			66

2.7. Data collection procedure

The survey was created by Google-Forms tool, which is commonly used by researchers for collecting data. Online structured questionnaire was developed for data collection. The online questionnaire is increasingly used as a main tool of data collection because it provides advantages to researchers such as speed response, lower respondent error, covers a wide range of potential respondents and low cost (Carcary et al., 2012). The questionnaire was sent via e-mail to the initial mailing list of the potential respondents. The online survey was done during 25th November 2018 to 20th of January 2019. All data submitted by respondents were anonymous which means the respondents didn't mention their name or other identifying information. However, respondents were asked to provide their email address if they want to receive a copy of a summary of the study's results.

After respondents completed the survey online, all answers were recorded and stored by Google-forms. The data was accessible by the researcher only. When the deadline was over and the survey was closed, the collected data was exported from Google-forms into a Microsoft Excel and then into SPSS for data analyzing.

2.8. Data analysis procedure

Data analysis was conducted to address the research questions, objectives and hypotheses. Data analysis was done by using Statistical Package for Social Science (SPSS) version 23 and the Analysis of Moment Structures (AMOS) software version 24. Before conducting data analysis, the data preparation was done on the completed questionnaires by editing, coding, entering and cleaning the data.

Descriptive statistics such as the frequency and percentage, mean, standard deviation, were used to provided data summarization of demographic characteristics of respondents. Also, the Pearson correlation coefficient was used to describe the correlations among the variables. To purify the instrument items confirmatory factor analysis (CFA) was carried out to assess the validity and reliability of the instrument by using convergent and discriminant validity. Also, Cronbach's Alpha was used to examine the reliability of the scale items. The overall model fit was assessed using seven goodness-of-fit indices, namely the chi-square/degree of freedom (χ^2/df) ratio, the comparative fit index (CFI), the Tucker-Lewis index (TLI), the Normed Fit Index (NFI), the goodness of fit index (GFI), the root means square error of approximation (RMSEA) and the expected cross-validation index (ECVI). In addition, Partial least squares structural equation modeling (PLS-SEM) was used to test empirically the proposed hypotheses.

2.9. Validity and reliability measurement

Validity is the extent to which an instrument measures are accurately measuring what it's designed and supposed to (Biddix, 2014). Reliability refers the extent to which an instrument measures a phenomenon provides stable and consist result (Carmines and Zeller, 1979). In this study and before testing the hypotheses reliability and validity of measurement scales were assessed by using confirmatory factor analysis (CFA). Hair et al., (2016) suggests that to

assess the reliability through PLS-SEM method, it is basic to examine the outer loadings of all constructs. He defined that the items with loadings in between .40 to .70 can be maintained. Also, this study used Cronbach's alpha coefficient to evaluate internal consistency of the scales. (Hair et al., 2010) stated that Cronbach's alpha coefficient for the constructs above 0.70 it is considered acceptable which indicates that all the items are internally consistent.

In order to measure the validity, this study used construct validity which refers to the extent to which a measurement scales can be transformed an idea, concept, or behavior that is a construct into a functioning and operating reality (Taherdoost,2016). In order to assess the construct validity, there are two methods which are suggested by (Fornell and Larcker,1981). The first method is convergent validity which refers to the extent to which a constructs are expected to be related are, in fact, related. Fornell and Larcker,(1981) proposed that to provided evidence for the convergent validity the item loadings should exceeded threshold value which is 0.50 with the significant t values and all the constructs have acceptable average variance extracted (AVE) and composite reliability (CR) values which are above 0.50 and 0.70 respectively.

The second method is discriminant validity which refers the extent to which latent variable discriminates from other latent variables (Duarte and Raposo, 2010). Two methods were used to assess discriminant validity. First, by using (Fornell and Larcker (1981) method which states that the square root of AVE of each variable should be greater than its correlations with any other construct. Second, if AVE for a latent construct is larger than the maximum shared variance with other latent constructs (Hair et al., 2010).

2.10. Structural equation modeling

Structural equation modeling SEM is commonly used in the social sciences because of its ability to explain the relationships between unobserved

constructs (latent variables) from observable variables (Henson and Roberts, 2006). Moreover, structural equation modeling (SEM) is a statistical technique that can use to reduce the number of observed variables into a smaller number of latent variables by testing the covariation among the observed variables. Structural equation modeling (SEM) provides a various type of models to assess relationships among observed variables, providing a quantitative test of a conceptual model hypothesized by the researcher. More specifically, the theoretical models can be tested in SEM that hypothesize how sets of variables explain constructs and how these constructs are related to each other (Schumacker and Lomax, 2010). SEM is comparable to common quantitative methods, such as correlation, multiple regression, and analysis of variance to estimate and test the relationships among constructs (Schreiber et al., 2006)

CHAPTER-THREE
THE IMPACT OF HUMAN RESOURCE
DEVELOPMENT ON
ORGANIZATIONAL EFFECTIVENESS

3.1. Introduction

Human resource development (HRD) is a relatively new area of professional practice and academic study. HRD has advanced beyond the narrow view of simply training and has evolved into a more complete approach to learning and developing knowledge at the individual and organizational level (Mittal, 2013). Leonard Nadler was the first to use the term HRD and he described it as a group of related activities completed in a given time period to produce a behavioral change. HRD can be defined as the process of developing and/or unleashing human expertise through organization development and personnel training and development for the purposes of improving performance (Swanson, 2001). The twenty-first-century challenges such as globalization, technology, and demographic changes have forced the organizations to strive constantly searching for innovative ways to achieving the superior results in terms of efficiency and effectiveness and improving competitiveness with current employees (Gberrvbie, 2012). As a result, the concept of human resource development (HRD) has emerged as a strategy to improve the competence of the employees and for enhancement of organizational effectiveness. The literature and previous studies (Swanson and Holton, 2009 and Bokeno, 2011) have confirmed that the success of an organization is extremely based on the skills, knowledge, and experience of its employees, which is a basic product of human resource development capability of that particular organization. Simonds and Pederson (2006) defined HRD as a combination of structured and unstructured learning and performance-based activities which develop individual and organizational competences, capability and capacity to cope with and successfully manage change. Federman (2006) stated that the concept of organizational effectiveness is concerning with issues such as the ability of an organization to access and optimal utilization of resources and consequently achieve its goals. Higher education organizations

have become more interested in implementing human resource development practices to improve their performance and sustain their leadership in competitive environment (Teir and Zhang, 2016). The integrated use of HRD practices within universities such as training and development, organizational development, talent development, and career development play key role in create new competencies, capabilities, and attitude that influence on employee's performance, in turn, enhance the performance of universities (Collins and Clark, 2003).

This present study tries to meet the need of the higher education sector in Iraq to such studies, for its influential role in society. The fact that this sector has the components of the application of colleges and institutes of government and private colleges. The lack of empirical research and there are no researches or studies have specifically dealt with examining how HRD practices effect on organizational effectiveness practically, in universities and institutes level. This study tries to address this gap.

3.2. Literature review and hypotheses development

3.2.1. Human resource development

The concept of human resource development was introduced in 1969 by Leonard Nadler through their participation in the Miami conference of the American society of training and development. Nadler (1969) states that there had been many scholars and researchers entering the HRD field and they deserved to have a definition of the subject. (Lee, 2001 and Wang and Swanson, 2008) argue that the definition of human resource development has long been challenged to define as it considers as a part filed of the human resources discipline. Ruona (2002) argues that human resource development definitions have been given attention in the literature for more than four decades. There are wide varieties of approaches that researchers attempted to define HRD. Although a universally accepted definition of HRD is non-existent. Human resource development is a relatively new area of professional

practice and academic study. Over the past two decades, human resource development has become the fastest growing area of management development, due to the great interest of organizations in the face of intense competition and changes in the business environment (Kareem, 2017). HRD has advanced beyond the narrow view of simply training and has evolved into a more complete approach to learning and developing knowledge at the individual and organizational level (Mittal, 2013). Swanson (2001) defines HRD as the process of developing and/or unleashing human expertise through organization development and personnel training and development for the purposes of improving performance. McLagan and Suhadolnik (1989) define HRD as the integration of training and development, career development, organizational development to improve individual, group, and organizational results. Rao (1985) defines HRD as a process that organizations must continuously use to assess the skills, abilities, and knowledge of human capital in order to proactively enable employees to have the required skills to meet the present and future job requirements within the organization. Wang et al. (2017) define HRD as any process or activity that, either initially or over the long term, has the potential to develop adult work-based knowledge, expertise, productivity, and satisfaction, whether for personal or group/team gain, or for the benefit of an organization, community, nation, or, ultimately, the whole of humanity.

As noted that the defining HRD is characterized in difficulty and complexity that reflects the evolving nature of the field. Also, the definition of human resource development is argumentative, it has traditionally been defined in the context of the individual, the work team, or the organization". The different definitions of HRD let to fully understand the term and also to recognize the fact that different sources describe this term in different ways. Regarding educational organizations, it is important to establish human resource development practices, especially for their academic staff. For the purpose of

this study, HRD is defined as a systematic process of educating and acquiring new skills, knowledge, and abilities of individual, group and organizations through the application of talent development, training and development, career development, and organizational development initiatives.

3.2.2. Human resource development in higher education organizations

Higher educational organizations, like every other organization, strive to sustain their competitiveness in today's changing business environment. Universities aim to meet the challenges in the market environment, and this effort require to develop its strategic resources. The idea of human resource development in educational institutions is a new trend. This could be because university academic staff are neende to be knowledgeable; therefore, more attention is paid to improve the competences of academic staff throughout HRD practices (Hamadamin and Atan, 2019). Popescu and Băltărețu (2012) argue that the effective use of HRD practices in educational institutions led to improve the employee's competences, skills, experience and personality as well as the development of other resources in the institution. In addition, (Srivastava et al., 2013) argue that for a higher educational organization there is a need to develop their human resources in a systemic way that will enable universities to use their tacit knowledge in order to improve their effectiveness and performance. For instance, the higher educational organizations in Iraq, the use of HRD practices is unclear. Iraqi universities are faced with the challenge of determining a framework that is suitable to the implementation of HRD (Hamadamin and Atan, 2019). Meanwhile, Emeagwal and Ogbonmwa, (2018) suggest that among other strategic resources that for a university to achieve superior performance strategic HRD practices must be effectively applied. Likewise, (Teir and Zhang, 2016) state that the strategies and plans for implementing an effective human resource development should take into

consideration improving the quality of educational services, and therefore contributing to the overall national growth.

3.2.3. Organizational effectiveness

The organizational effectiveness (OE) is a powerful and critical concept of organizations as a result of rapid development and extreme competition for the survival and continuity. Many researchers and scholars (Abu El Khair, 2016; Gold et al,2001; Cameron, 1980) have strived to find a theory adopted by the organizations to be effective, but the subject of effectiveness is complex and this led to a lot of differences in the definition of the concept and identify the measurements of the organizational effectiveness that may be due to the difficulty of identifying the phenomena surrounding the effectiveness of the organizations. Barnard (1938) is the first researcher who has attempted to provide a definition of organizational effectiveness where he defined the organizational effectiveness is any activity associated with the success of achieving the objective for which this activity was established.

Cameron (1986) argues that in the literature, there is still significant lack of agreement on the definition of this concept. There are wide varieties of approaches that researchers attempted to define organizational effectiveness as (Georgopoulos and Tannenbaum, 1957) define organizational effectiveness as the extent to which an organization as a social system, given specific resources and means, accomplishes its objectives without incapacitating its means and resources and without placing undue strain upon its members. Daft (1992) states that OE is the ability of the organization to invest its environment in acquiring or obtaining scarce and valuable resources for its functioning. Roy and Dugal (2005) argue that OE is the net satisfaction of all constituents in the process of gathering and transferring inputs into outputs in an efficient manner. Tabeel (2013) defines OE as the ability of the organization to achieve its

objectives under the specified resources available through achieving job satisfaction and ensuring the survival and development of the institution.

In this context, the researcher defines the organizational effectiveness as the ability of an organization to achieve its goals, stability, productivity of the organization, adapt to the changing business environment, workforce development, and optimal utilization of resources. Cameron (1980) states that the evaluation of organizational effectiveness requires selecting the appropriate criteria. The literature and scholars have developed varieties of models to indicate and measure the effectiveness of higher education organizations such as (Shah, 2016) in his study proposed six indicators to measure the organizational effectiveness are: motivation, organizational commitment, organizational attachment, organizational innovation, consensus and job involvement. While (Kaur, 2013) proposed four indicators to measure the organizational effectiveness are production, efficiency, satisfaction, and organizational development. Gold et al (2001) state the dimensions of organizational effectiveness include innovation, coordination, and rapid commercialization of new products.

3.2.4. Organizational effectiveness approaches

(Balduck and Buelens, 2008; and Potnuru and Sahoo,2016) argue that organizational effectiveness can't be measured by a single approach only, as it is a multi-approach concept. In the literature, there are four key approaches for measurement of organizational effectiveness: goal approach; system resource approach; strategic constituency approach; and competing values approach. For the purpose of this study, the researcher designed three approaches to measure the effectiveness of higher education organizations based on some literature such as (Gold et al., 2000; Rahman et al., 2013; Banat,2002; Abu El Khair, 2016). First, goal approach measures the extent to which, the organization is effective in achieving its stated goals. Second, system resource

approach measures the ability of the organization to acquire necessary resources from its environments. Third, a competing values approach measures the organization's ability to adaptation to the changing business environment and emphasis on optimization of resources, stability, and flexibility.

3.2.4.1. Goal approach

In light of this approach, the effectiveness of the university is seen to the extent that the university achieves its objectives. This approach is based on the basic idea that all organizations have a number of goals and become criteria for measuring effectiveness. This approach focuses on the objectives that the organization is trying to achieve and an attempt to guess the extent to which these goals are achieved (Lee, 2006) and (Robbins, 2003).

3.2.4.2. System resource approach

This approach focuses on the university's ability to exploit its environment to obtain scarce and valuable resources, for the purpose of using it effectively to achieve the goals set and to maintain balance and stability (Cameron, 1978). (Wolfe and Putler, 2002; Banat, 2002) state that the effectiveness of the university in this approach is primarily related to the extent to which that organization is able to obtain or to attract the necessary resources to ensure its sustainability and maintain its survival. The higher organization's performance in the process of obtaining the necessary resources from the external environment, it leads to efficiency. So, OE its ability to collect the best sources from the external environment, thus focusing on inputs (resource mobilization) as a basic measure of effectiveness rather than output.

3.2.4.3. Competing values approach

This approach assumes that there is no ideal criteria for measuring organizational effectiveness so. organizations can be evaluated in different ways depends on the personal values of the evaluators (Quinn and Rohrbaugh, 1981). Also, Robbins (1990) states that this approach assumes that people

within the organization have goals may be based on personal values, preferences, and interests and therefore cannot arrive at a consensus on which goals take precedence over others. Campbell (1977) proposes seventeen variables of competing values approach of organizational effectiveness and linked together to create three basic sets of competing values. Quinn and Rohrbaugh (1981) provide the three competing values. The first set of values is to deal with flexibility versus control. The second values are to deal with people versus the organization and, the third set of values is to deal with means versus ends.

3.2.5. Human resource development contributions to organizational effectiveness

Several researchers and scholars of human resource development tried to examine and highlight the relationship between human resource development and organizational performance and effectiveness. Otoo and Mishra (2018) explores the influence of human resource development practices on organizational effectiveness by considering the role of employee competencies. He found out that HRD practices have an impact on employee competencies in enhancing organizational effectiveness. Potnuru and Sahoo (2016) examine the impact of human resource development interventions on organizational effectiveness by means of employee competencies. He stated that HRD interventions have a significant impact on the building of employee competencies which are positively improving organizational effectiveness. Alagaraja et al. (2015) investigate the effects of human resource development contributions on organizational performance. Both types of HRD contributions strategic value and transaction effectiveness significantly enhanced organizational performance. Alagaraja (2014) states that both HRD and HRM have a critical contribution to the development, furthering of knowledge, and application of theories in improving HR service delivery and its impact on

organizational performance. Alagaraja (2013) argues that the significance and power of human resource development based on its ability to engage and respond to stakeholder expectations and involvement in organizational change efforts. Nilsson and Ellstrom (2012) state that human resources development strategies in an organization play a key role in improving employees' competencies that contribute, in aggregate to organizational performance.

3.2.6. Components of human resource development

The literature and scholars have developed varieties of components to indicate the HRD. (Mafi, 2000; Hassan, 2007; Sabarina, 2015; Potnuru and Sahoo, 2016) argue that HRD has three elements i.e. training and development, organizational development, and career development. Tomé (2011) states that HRD has four elements such as training and development, organizational development, and career development and performance development. The varieties of components of HRD allow researchers the flexibility to explore and identify specific constructs and variables on different aspects of shaping and skilling for scholarly inquiries. This study examines the effect of four HRD practices: talent development, training and development, organizational development and career development on organizational effectiveness. For the purpose of testing the demonstrated hypotheses H1, H2, H3 and H4 which are discussed below.

3.2.7. Talent development and organizational effectiveness

Talent management and talent development have been increased as important to the success of organizations. As results in globalization, mobile workforce, and empowered workforce. Talent professionals today work in a dynamic environment that requires developing of talent strategy if the organization wants to increase the potential of its workforce (Fitzgerald, 2014). Employee talent development is one of the challenges that has become a potential main source of competitive advantage and sustainability. It is significant for the

organization and plays a key role in identifying and encouraging their workforce who have the capability and potential (Ingham, 2006). Gallardo et al. (2013) state that talent can be demonstrated as a concept of natural ability, mastery, commitment, and fit, which are evident as innate abilities, acquired skills, knowledge, and attitudes whereby better outcome can be achieved. According to Annakis et al. (2014), talent development is a systematic process of developing and integrating new workers, developing and retaining current workers, and attracting highly skilled workers to work for a company and it's beneficial to the organization. Lewis and Heckman's (2006) state that talent development is a collection of practices of human resource department within the organization which are concerning with rewarding, sourcing and developing the talent of the employee. According to Jantan et al. (2009), talent management can be defined as a consequence to ensure the right person is in the right job; process to ensure leadership continuity in key positions and encourage individual advancement, and decision to manage supply, demand, and flow of talent through a human capital engine. In this context, the researcher defines talent development as a systematic process of attraction, identification, development, and retention of those individuals with high potential who are of particular value to an organization. Based on the above discussion, the first hypothesis can be derived as follows :

H1: Talent development has a positive influence on organizational effectiveness.

3.2.8. Training and development and organizational effectiveness

Training and deployment play a key role in the achievement of an organizational goal through integrating the interests of the organization and the workforce. Nowadays training and development is a very significant factor in the business world because it enhances the efficiency and the effectiveness of both employees and the organization (Khan et al.,2011). Noe (2001) states that

organizations that adopt training and development practices are able to retain their customers, suppliers, employees, shareholders, and other stakeholders in the long run as they are deemed more trustworthy and better custodians of the interests of the various stakeholders. Biswas (2012) argues that training and development is fundamental for the superior performance of employees, improvement of employees' ability to adapt to the changing and challenging business environment and technology for better performance, increase employees' knowledge and ability to develop creative and problem-solving skills. Training and development is a part of the human resource development function. Training and development have an important role to address the gap between current performance and expected future performance of the employees (Weil and Woodall, 2005). Sims (2002) states that training focuses on current jobs while development makes employees for possible future jobs. Essentially, the training and development aims to enhance the organization's overall goal. Armstrong (2003) defines the training and development is a systematic process designed by the organization to improve the current and future employee performance by increasing an employee's skills, knowledge and ability to perform through learning activities, changing the employee's attitude and behavior.

In this context, the training and development is a systematic process of increasing an employee's ability to perform through learning and changing the worker's attitude and behavior and improving their skills and knowledge in order to enable the organization to achieve its strategic objectives. Human resources departments should pay efforts to the training and development programs to their organizational success. Also, training programs may be led to improved profitability, positive attitudes toward profit orientation, improve the job knowledge, ability, and skills at all levels of the organization, motivate the employees and engage them with organizational goals. Based on the above contribution, the second hypothesis can be derived as follows:

H2: Training and development have a positive influence on organizational effectiveness.

3.2.9. Organizational development and organizational effectiveness

In today's rapidly changing business environment and global competition, organizations are facing difficulties in operating at an optimum level. Hence, the emergence of organizational development as today's changing environment in order to compete, survive and perform a wide range of activities in order to adapt to environmental changes (Roodposhti, 2007). Azari et al. (2014) state that organizational development is a systematic use of behavioral science to develop the planned progress, improve, and emphasize on strategies, structures, and organizational processes for improvement of organizational effectiveness. According to Dobrai and Farkas (2015) organizational development is a planned wide-range effort, that includes the organization as a whole, and it aims to enhance effectiveness and sustainability of the organization through imperative planning into organizational processes. Al-aldaea (2016) argues that organizational development is a comprehensive and integrated concept that is used to address the insufficiency and ineffectiveness of the organization. It is a planned effort to change the attitudes, culture, values of individual and collective work, leadership, organizational structure technology, and decision-making. It is also an institution-based approach as a whole system, provides adaptation to the changes in the environment. Omayan (2005) states that organizational development is a long-term effort to improve the organization's capacity to solve problems and renew its operations through comprehensive development of the Organization's climate, with particular emphasis on increasing the effectiveness of its workforce by using human resource development practices. In this context, the researcher defines organizational development as is a system-wide application is designed to develop the employees through changing their values, skills, and behavior, as

well as change the used technology and organizational structure. Based on the above discussion, the third hypothesis can be derived as follows:

H3: Organizational development has a positive influence on organizational effectiveness.

3.2.10. Career development and organizational effectiveness

In an organizational context, career development is basically considered as a crucial human resource development function (Osman et.al,2014). Prince (2005) argues that career development is a function of human resource development which focuses on developing and enhancing the organization's workforce in light of both the organization and individual's needs. Amah (2006) defines career development is the process of promoting organizational employees' knowledge, abilities, and skills to prepare them for new opportunities and challenges.

Career development is basically negotiable values, expectations, and objectives of employees related to their career advancement, combined with the needs and goals of the organization in order to create an efficient working relationship among them (Orpen, 1994). Eisenberger et al. (1999) state that career opportunities and promotion have a positive effect on organizational support. Career development positively impacts on career success and career satisfaction. Chetana and Mohapatra (2016) argue that career development entails initiatives from both the individual and organization. The organization must be aware of its individuals' career needs. Individuals should identify their knowledge, abilities, skills, and interest in order to explore their career path. So, organizations while setting up a strategic career development program should take on account the competencies that can enhance the employee's career. In this context, career development is a lifelong process of identifying the individual interests, competencies, activities, and job assignments required to develop individual employee skills for future needs of the organization.

Based on the above contribution, the fourth hypothesis can be derived as follows:

H4: Career development has a positive influence on organizational effectiveness.

Figure (4) demonstrates the hypothesized research model which proposes that HRD constructs i.e. talent development, training and development, organizational development, and career development have a positive influence on organizational effectiveness.

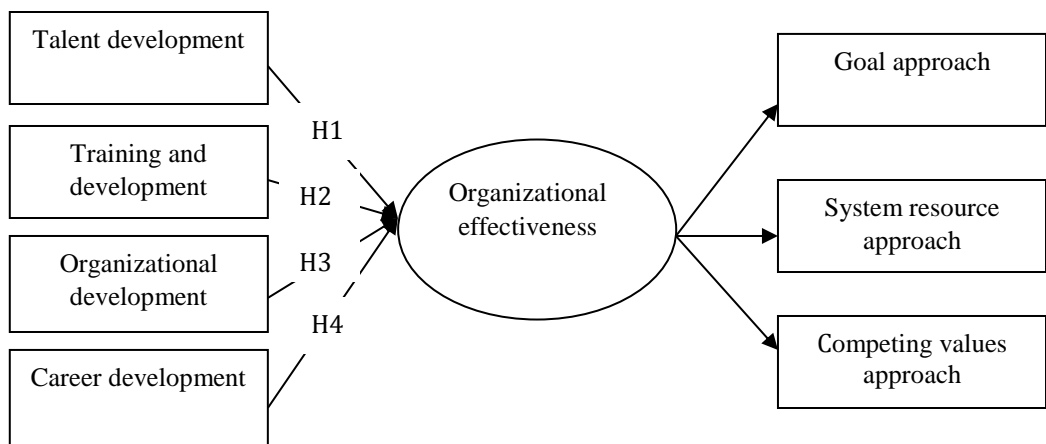

Figure 4. A proposed research model of HRD and OE
Source: researcher own construction

3.3. Research Methodology

3.3.1. Research design, sampling and data collection

This research was used quantitative design. A quantitative design is suitable to use in hypotheses testing of the relationship between independent and dependent variables (Sekaran and Bougie, 2013). The purpose of this quantitative design study was to determine the extent to which does HRD practices i.e. talent development, training and development, organizational development and career development influence organizational effectiveness. This study adopted the survey method to collect the primary data. Creswell (2013) argues that researchers and scholars adopt a quantitative research often

employ survey method because it is considered an economical and efficient method to gather quantitative . According to Grohmann and Kauffeld (2013) questionnaire is often used while adapting survey method. The survey was created by google-forms tool, which is commonly used by researchers for collecting data. The web-based questionnaires were distributed through E-mail designed to collect the primary data from the employees of the selected Iraqi public universities including a number of deans, heads of departments, faculty members and administrative staff which seems to provide a corresponding sample for conducting data collecting and analyzing. The questionnaire was distributed to around 342 employees, out of which 215 completed questionnaires were obtained, with response rate of 62.86 % of the respondents. The demographic data of the respondents are showed in table 2. Out of the 215 respondents, (76.74%) were males and (23.25%) females. The majority of the respondents (44.65%) were in the age category within 31-40 years. Most of the respondents at (61.86%) were non-executive designation and (38.13) were an executive designation. The majority of the respondents (47.44%) were holders Ph.D. degree while (40.46%) were holders master’s degree and (12.93%) were holders bachelor’s degree. A little lower than half of the respondent (41.39%) had work experience 11-20 years.

Table 2. The demographic data of the respondents

Item		Frequency	Percentage
Gender of the respondent	Male	165	76.74
	Female	50	23.25
Age of the respondent	20-30 years	34	15.81
	31-40 years	96	44.65
	41-50 years	65	30.23
	51-60 years	14	6.51
	More than 61 years	6	2.79
Designation	Executive	82	38.13
	Non-Executive	133	61.86
Educational achievements	Bachelor’s Degree	26	12.93
	Master’s Degree	87	40.46

	Ph.D. Degree	102	47.44
Work Experience	Less than 5 years	31	14.41
	5-10 years	63	29.30
	11-20 years	89	41.39
	More than 21 years	32	14.88

Source: researcher own construction

3.3.2. Instrumentation development and measures

The questionnaire comprises of two sections (see Table 6). Section one collects participant and institutional background information of the respondents such name of the university, age, gender, a position held, educational attainment, work experience, and organization size. Section two includes questions are designed to measure the variables of the study by using a comparative seven-point Likert-type scale ranging from 1-7, in which, 1 = strongly disagree, 7 = strongly agree. Moreover, 20 items are designed to measure HRD constructs as follows: according to (Mahfoozi et al.,2018) 5 items were developed to measure talent development as the organization's ability to attraction, identification, development, and retention of talented individuals. 5 items are adopted from (Asfaw et al.2015) were used to measure training and development as the organization's ability to increase an employee's ability perform through learning, changing the employee's attitude and increasing their skills and knowledge in order to enable the organization to achieve its strategic objectives. According to (Rastgoo, 2016) and (Zadeha and Ghahremanib, 2016), 5 items were developed to measure the organizational development which measure the organization's ability to improve, reinforcement of the strategies, structures, and processes in order to improve organizational effectiveness. Career development was measured by 5 items adopt from (Weng and McElroy, 2012) and (Xueling, 2017) were measured the organization's ability to identifying the individual interests, competencies, activities, and job assignments required to develop individual employee skills for future needs of the organization. Finally, According to (Banat,200212; Abu

El Khair, 2016; Gold et al., 2001 and Rahman et al., 2013) 12 items are designed to measure the organizational effectiveness constructs which are goal approach, system resource approach, and competing values approach.

Cronbach 's alpha coefficient was used to evaluate the internal consistency of the scales where Cronbach's alpha coefficient for all the constructs ranges between 0.874 and 0.953 and it is considered acceptable which indicates that all the items are internally consistent. Table (3) shows detailed information regarding the variables, sources, number of the items and Cronbach's alpha as follows:

Table 3. the study measures in regard to the sections of the questionnaire, sources, and Cronbach's alpha

sections	Name of the variable	Source	Number of items	Cronbach's alpha
section one	participant and institutional background information	Researcher developed	9	
Section two	Talent development	(Mahfoozi et al.,2018)	5	0.946
	Training and development	(Asfaw et al.2015)	5	0.932
	Organizational development	(Rastgoo, 2016) and (Zadeha and Ghahremanib, 2016)	5	0.947
	Career development	(Weng and McElroy, 2012) and (Xueling, 2017)	5	0.953
	Goal approach	(Banat,2002)	4	0.931
	System resource approach	(Abu El Khair, 2016)	4	0.874
	Competing values approach	(Gold et al., 2001),(Rahman et al., 2013)	4	0.936

Source: researcher own construction based on the mentioned literature

3.3.3. Data analysis procedure

Data analysis was conducted to address the research questions, objectives and hypotheses and was done by using Statistical Package for Social Science (SPSS) version 23 and the Analysis of Moment Structures (AMOS) software

version 24. Before conducting data analysis, the data preparation was done on the completed questionnaires by editing, coding, entering and cleaning the data. Descriptive statistics such as the frequency and percentage, mean, standard deviation, were used to provided data summarization of demographic characteristics of respondents. Also, the Pearson correlation coefficient was used to describe the correlations among the variables. To purify the instrument items, confirmatory factor analysis (CFA) was carried out to assess the validity and reliability of the instrument by using convergent and discriminant validity. Also, Cronbach's Alpha was used to examine the reliability of the scale items. The overall model fit was assessed using seven goodness-of-fit indices, namely the chi-square/degree of freedom (χ^2/df) ratio, the comparative fit index (CFI), the Tucker-Lewis index (TLI), the Normed Fit Index (NFI), the goodness of fit index (GFI), the root means square error of approximation (RMSEA). Also, partial least squares structural equation modeling (SEM) was used to test empirically the proposed hypotheses. SEM is commonly used in the social sciences because of its ability to explain the relationships between unobserved constructs (latent variables) from observable variables (Henson and Roberts, 2006). SEM is comparable to common quantitative methods, such as correlation, multiple regression, and analysis of variance to estimate and test the relationships among constructs.

3.4. Results

3.4.1. Descriptive statistics

Table 4 presents a descriptive analysis of the data and the correlations matrix among variables. The means, standard deviations, and correlation matrix are presented. The mean score for HRD practices (TD, T&D, OD, CD) and organizational effectiveness constructs (GA, SRA, CVA) is located between (3.29-3.80) and standard deviation (1.48-1.62) that indicates a good implementation of HRD practices in enhancement organizational effectiveness

of in the public universities of Iraq. Also, the results show that each of the constructs is positively and significantly correlated to each other.

Table 4. Descriptive and correlation results

	Mean	S. D	TD	T&D	OD	CD	GA	SRA	CVA
TD	3.29	1.59	1.000						
T&D	3.49	1.56	.778**	1.000					
OD	3.46	1.60	.777**	.823**	1.000				
CD	3.35	1.59	.755**	.795**	.832**	1.000			
GA	3.80	1.62	.733**	.839**	.859**	.788**	1.000		
SRA	3.44	1.48	.701**	.793**	.767**	.715**	.853**	1.000	
CVA	3.80	1.53	.629**	.694**	.703**	.695**	.771**	.743**	1.000

** Correlation is significant at the 0.01 level (2-tailed).

TD=Talent Development, T&D=Training and Development, OD=Organizational Development, CD=Career Development, GA=Goal Approach, SRA=System Resource Approach, CVA=Competing Values Approach

Source: researcher own construction

3.4.2. Reliability and Validity

In this study and before testing the hypotheses reliability and validity of measurement scales were assessed by using confirmatory factor analysis (CFA) to estimate the convergent validity, discriminant validity and goodness of fit statistics. The reliability of the scales was evaluated using Cronbach's alpha coefficient. As it is seen in table 5, Cronbach's alpha coefficient for all constructs ranges between 0.874 and 0.953 and it is considered acceptable which indicates that all the items are internally consistent (Hair et al., 2010). In order to determine the convergent validity, there are three important indicators of convergent validity are factor loadings (standardized estimates), Average Variance Extracted (AVE) and Composite Reliability (CR). Hair et al. (2006) suggest that the items with loadings in between .50 to .70 can be maintained. This study investigates that the item loadings all exceeded the threshold value and statistically significant ($p < 0.05$). (see table 8). Composite reliability (CR) for all constructs ranges between 0.872 and 0.955 which are above 0.50 that indicates that all the constructs have a good level of composite reliability (CR) as recommended by (Hair et al., 2012). The average variance extracted (AVE) value for all the constructs are in the range between .618 to

.808 which are above the threshold value .50 which is suggested by (Hair et al., 2010).

Table 5. Constructs evaluation

Constructs	Measurement Items	Factor Loading	CR	AVE	P.Value
Talent Development	TD5	0.852	0.947	0.780	.000
	TD4	0.884			.000
	TD3	0.896			.000
	TD2	0.898			.000
	TD1	0.852			.000
Training and Development	T_D5	0.807	0.932	0.732	.000
	T_D4	0.902			.000
	T_D3	0.886			.000
	T_D2	0.855			.000
	T_D1	0.827			.000
Organizational Development	OD5	0.9	0.948	0.785	.000
	OD4	0.9			.000
	OD3	0.904			.000
	OD2	0.875			.000
	OD1	0.85			.000
Career Development	CD5	0.854	0.955	0.808	.000
	CD4	0.952			.000
	CD3	0.904			.000
	CD2	0.922			.000
	CD1	0.861			.000
Goal Approach	GA4	0.901	0.932	0.789	.000
	GA3	0.837			.000
	GA2	0.904			.000
	GA1	0.91			.000
System Resource Approach	SRA4	0.883	0.872	0.618	.000
	SRA3	0.733			.000
	SRA2	0.722			.000
	SRA1	0.797			.000
Competing Values Approach	CVA4	0.904	0.936	0.771	.000
	CVA3	0.94			.000
	CVA2	0.824			.000
	CVA1	0.841			.000

CR =Composite Reliability and Average, AVE=Variance Extracted

Fornell and Larcker (1981) method was used to assess discriminant validity. He suggested that to support for discriminant validity if the square root of the AVE for a latent construct is greater than the correlation values among all the latent variables. Table (6) shows that the square root of the AVE values of all the constructs are greater than the inter-construct correlations which supports the discriminant validity of the constructs. Also, the goodness-of-fit statistics of the measurement model indicated a good fit to the data (CMIN/df=1.903, GFI=.0.913, TLI=.909, CFI=.901, RMSEA=.084). Thus, the measurement model reflects good construct validity and desirable psychometric properties.

Table 6. Discriminant validity of the constructs

	TD	T_D	OD	CD	GA	SRA	CVA
TD	0.883						
T_D	0.823	0.858					
OD	0.816	0.857	0.886				
CD	0.785	0.827	0.866	0.899			
GA	0.798	0.836	0.821	0.850	0.880		
SRA	0.788	0.848	0.871	0.808	0.857	0.795	
CVA	0.0685	0.744	0.754	0.737	0.841	0.745	0.886

Notes: Bold values in diagonal represent the squared root estimate of AVE. TD=Talent Development, TandD=Training, and Development, OD=Organizational Development, CD=Career Development, GA=Goal Approach, SRA=System Resource Approach, CVA=Competing Values Approach.

Source: researcher own construction

3.4.3. Test of hypotheses

The proposed model indicates that HRD constructs i.e. (talent development, training and development, organizational development and career development) have an influence on organizational effectiveness within the investigated Iraqi universities. Structured equation modeling (SEM) was used to test this hypothesized model. The results (Table 7 and figure 5) show that all the four hypothesized relationships between HRD practices and organizational effectiveness are significant and thus all the hypotheses are supported. Moreover, the positive significant relationships include, (1) talent development and organizational effectiveness ($\beta=0.13$, $p<0.044$) supporting H1; (2) training

and development and organizational effectiveness ($\beta=0.57$, $p<0.000$) confirmed H2; (3) organizational development and organizational effectiveness ($\beta=0.63$; $p<0.000$) that supports H3; (4) career development and organizational effectiveness ($\beta=0.20$, $p<0.000$) confirming H4.

Table 7. Result of hypothesis analysis

NO.	Hypotheses	Beta Coefficient	P.Value	Result
H1	Talent development → Organizational effectiveness	0.13	0.044	Supported
H2	Training and development → Organizational effectiveness	0.57	0.000	Supported
H3	Organizational development → Organizational effectiveness	0.63	0.000	Supported
H4	Career development → Organizational effectiveness	0.20	0.003	Supported

Source: researcher own construction

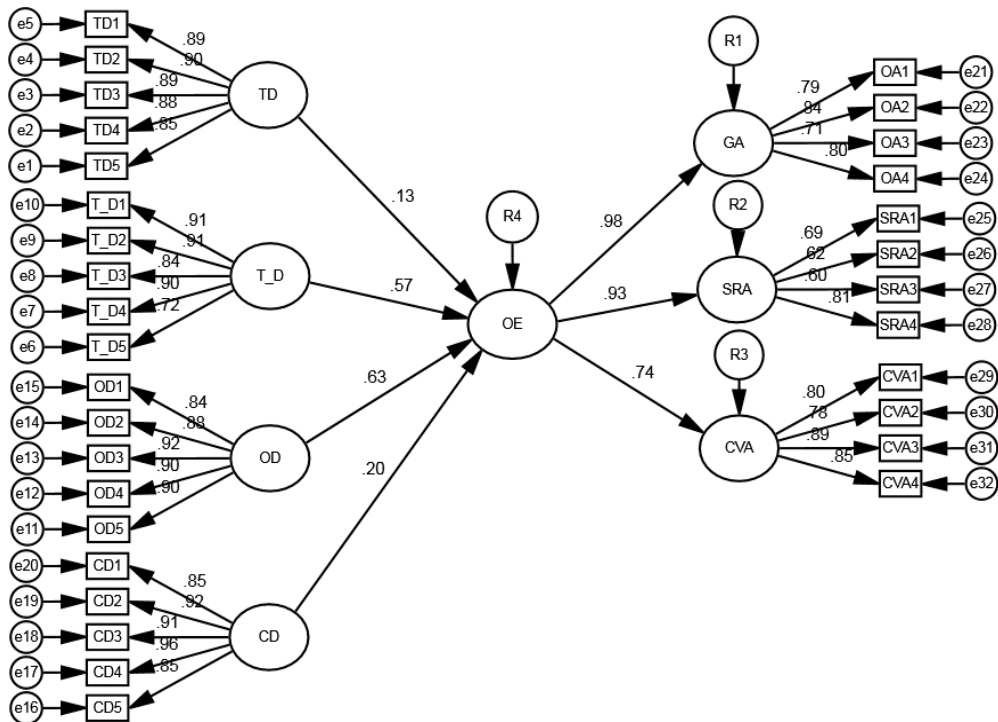

Figure 5. The SEM model analysis of HRD and OE

Source: researcher own construction

3.5. Discussion and conclusions

Due to the lack of empirical researches or studies have specifically dealt with examining how HRD practices effect on organizational effectiveness practically, in universities and institute level, this study tries to address this gap. The aim of this study is to investigate the influence of HRD practices (divided into four main components: talent development, training and development, organizational development and career development) on organizational effectiveness in the context of public universities of Iraq. The results show that all the HRD practices are significant predictors of organizational effectiveness. The results confirmed that all the four hypothesized relationships between HRD practices (talent development, training and development, organizational development and career development) and organizational effectiveness are significant and thus all the hypotheses are supported. Moreover, the results verified the hypothesis H1 by showing that talent development has a significant influence on organizational effectiveness. Which supports opinions of (Bayyurt and Rizvi 2015). The second hypothesis H2 also have similar result shows a significant positive relationship between training and development and organizational effectiveness. Which is in line with the suggestions of (Asfaw et al.2015). The results confirmed the third hypothesis H3 by showing that organizational development significantly affects organizational effectiveness. Which supports the opinion of (Al-aldaaja, 2016). The results of the final hypothesis H4 confirms that career development has a significant influence on organizational effectiveness. Which is in line with (Zaina, 2019) opinions.

In general, findings of this current study are in the line with (Alagaraja et al.,2015) and (Nilsson and Ellstrom,2012) stated that human resources development practices in an organization play a key role in improving employees' competencies that enhance to organizational performance.

Findings support that if the universities develop an effective HRD program for their employees to improve their knowledge skills and abilities that led to enhance organizational performance.

3.5.1. Theoretical contributions of the study

Although, HRD and organizational effectiveness have drawled attention in the literature but, there is a lack of empirical researches or studies have specifically dealt with examining how HRD practices effect on organizational effectiveness practically, in universities and institute level. Therefore, this study tries to address the gap and under-explored issues in the literature in several ways. First, this study developed an empirical research model for the literature and empirical studies in the field of HRD practices, organizational effectiveness, and the link between HRD practices and organizational effectiveness. Second, this study measured two important organizational processes. Thus, it shows that HRD and organizational effectiveness are measurable and applicable processes. Third, the study attempts to empirically test the impact of HRD practices on organizational effectiveness. The findings suggest that HRD practices i.e. (talent development, training and development, organizational development and career development) have a significant positive impact on organizational effectiveness. Thus, this study provides a better understanding of the relationship between HRD and organizational effectiveness.

3.5.2. Managerial implications of the study

In terms of managerial implications, this study has confirmed the significance of HRD practices and how they are positively related to organizational effectiveness. The results of this study have the potential to help the decision-makers of universities to develop effective HRD practices which will enable them to improve employees' competencies in enhancing organizational effectiveness. Also, this study recommends universities' managers to use

effective HRD practices which are aimed at building excellent employees' competencies and increase the integration between human resource development and organizational effectiveness. Lastly, this study emphasizes the important role of HR managers in stimulating the employee's skills, knowledge, and abilities which are necessary to perform the required job efficiently.

3.5.3. Limitations and future research

Despite the significant contributions of this study but, it has some limitations that need to be addressed. First, this study focuses on the selected Iraqi public universities context, which may be different from others. Second, this study adopts a cross-sectional research method for data collection, which does not allow the researcher to examine the causality of the relationships between HRD and organizational effectiveness in greater depth. Finally, this study is limited because it focuses on four HRD practices as the major predictors of organizational effectiveness, other HRD practices may be significantly explained organizational effectiveness. In this regard, future research may include other potential practices of HRD and other attributes of organizational effectiveness. In addition, the possible mediating role of other variables, such as dynamic capabilities the relationship between HRD and organizational effectiveness.

CHAPTER- FOUR
THE IMPACT OF DYNAMIC
CAPABILITIES ON ORGANIZATIONAL
EFFECTIVENESS

4.1. Introduction

The global competition and the rapid growth of the knowledge economy in highly changeable environment has encouraged the organizations to develop a paradigm to understand how to sustain their competitiveness and achieve superior organizational effectiveness. One of the vital efforts to address that challenges is the dynamic capabilities approach (Rao, 2016). The concept of dynamic capabilities is a relatively novel concept, which has provided foundations of how organizations are renewed its internal and external competences to address to environmental turbulence. The dynamic capabilities have emerged from the resource-based view (RBV) of the firm which explains that unique, inimitable and rare resources are core source of superior performance, and achieve sustained competitive advantage (Barney, 1991; Teece al. 1997; Eisenhardt and Martin, 2000). Teece, al. (1997) defined dynamic capabilities as the firm's ability to integrate, build, and reconfigure internal and external competencies to address rapidly changing environments. Dynamic capabilities play key role in matching organization's external opportunities with internal strengths through integrate, build, and reconfigure of internal resources, they ensure sustainable competitive advantages and maintained organizational effectiveness (Teece, 2007). In the last decade or so, this significance of dynamic capabilities has attracted many of researchers (Zollo and Winter, 2002; Li and Liu, 2014; Zahra et al., 2006 and Barreto, 2010). Some researchers investigated empirically the relationship between dynamic capabilities and firm performance (Danneels, 2012; Wilden et al.,2013 and Protogerou et al.,2012). Despite the increased attention on dynamic capabilities but, there is still confusion about how dynamic capabilities influence organizational effectiveness.

This study aims to investigate the relationship of dynamic capabilities and organizational effectiveness in the selected Iraqi public universities context.

A few studies that explored dynamic capabilities in higher education's institutes context (Gallardo and Navarro,2003; Takahash et al.,2016; Bejinaru,2017), but no one has specifically dealt with examine how dynamic capabilities effect on organizational effectiveness. This study tries to address this gap through proposing an empirical model that dynamic capabilities constructs i.e. sensing capabilities, learning capabilities and reconfiguration capabilities have a positive influence on organizational effectiveness. This article contributions to the literature in two ways. First, it reviews the dynamic capabilities concept using three dimensions i.e. sensing capabilities, learning capabilities and reconfiguration capabilities may that contributions in further investigation of the nature and dimensionality of dynamic capabilities and their role in the business context. Second, it exams empirically the link between dynamic capabilities and organizational effectiveness in the selected Iraqi public universities context.

The remainder of the article is organized as follows: the first section presents the objectives, research questions, hypotheses and proposed model of the study. Second section presents the literature review. Third section presents the research methodology. Fourth section presents the data analysis and results. The last section presents discussion of the findings including theoretical and practical implications, study limitations and future research.

4.2. Literature review and hypothesizes development

4.2.1. Dynamic capabilities

The concept of dynamic capabilities has emanated from the resource-based view (RBV) for its ability to meet rapid environmental changes (Teece, 2007). Since the initial introduction of the concept by (Teece et al., 1997) is gaining greater attention in the literature. He defines dynamic capabilities as a firm's ability to integrate, build and reconfigure internal and external competencies to address rapidly changing environments. Further, (Eisenhardt and Martin,

2000) describe dynamic capabilities are a set of specific and identifiable processes such as product development, strategic decision-making, and alliancing. Dynamic capabilities are distinctive in their details and path-dependent on their emergence; they have significant commonalities across firms. (Zollo and Winter, 2002) define dynamic capabilities as a learned and stable collective processes enable organization systematically creates and modifies its operational activities in order to improve effectiveness. (Zahra and George, 2002) state that dynamic capabilities are basically changing-oriented capabilities that enable firms to renew and reconfigure their resource base to meet evolving customer demands and competitor strategies. More recent (Rao,2016) describes dynamic capabilities as firm's capability to manage alliances, learn, integrate and reconfigure resource base to address the changing business conditions.

The literature discussed on dynamic capabilities is confused with discrepancies and overlapping definitions. Several scholars suggest to better understand the nature of dynamic capabilities is distinguish between dynamic and operational capabilities. (Helfat et al., 2007) distinguish between dynamic and operational capabilities. They state that operational capabilities firm ability to perform their everyday functional activities, while dynamic capabilities are used to maintain the current status. (Teece, 2007) explains that operational capabilities are organizations ability to maintain its technical competences by ensuring the efficiency of its operational activities, while dynamic capabilities help a firm's to sustain evolutionary competences by enabling the build, renewal, and reconfiguration of its resource base, thereby achieve sustainable competitive advantage. In results, dynamic capabilities are organization capacity enabling the creation, extension, and modification of its operational capabilities systematically (Protogerou et al.,2012).

4.2.2. Building dynamic capabilities in higher education organizations

Higher education organizations, operate as a businesslike organization are facing some challenges in the dynamic and complex competitive business environment. These challenges could be the privatization of the educational system, the shifts in the labor market the requirements, and national and international competition (Mahdi et al., 2019). The Iraq educational system is not an exception to these challenges. Today universities are not only educating and doing research but also trying to take advantage of the knowledge they produce, which reveals a new mode of knowledge production. Universities play a vital role in knowledge production, which are expected to supply knowledge, to produce innovation, to support entrepreneurship, to be leaders both in business and society (Bejinaru, 2017). Also, higher education organizations play a key role in the so-called knowledge economy. The success in the knowledge economy depends on the interaction and cooperation of higher education organizations with industry and government which, under the so-called triple helix model (THM) (Rodriguse and Melo, 2013) Based on this approach universities must become entrepreneurial organizations aimed at doing the translation of research into products and new firms.

Thus, there is a great need in developing dynamic capabilities for the prosperity of the university. The dynamic capabilities in the universities context play a vital role in building capacity to respond to social needs, efficiency, effectiveness, and quality. An environmental changes and greater social demands are forcing universities to implement a process of change that requires continuous improvement and the creation of dynamic capabilities (Gallardo and Navarro,2003). In the rapidly changing educational circumstances, educational leadership needs to develop dynamic capabilities by integrating and reconfiguring their internal and external resources and

competencies to address environmental changes (Johara, 2018). Moreover, Takahashi et al., 2016) confirm empirically that the dynamic capabilities significantly impact on universities performance.

4.2.3. Dynamic capabilities contribution to organizational effectiveness

The impact of dynamic capabilities on organizational effectiveness has been an attractive issue among scholars. However, the way that dynamic capabilities affect organizational effectiveness is still under investigation. Also, the empirical studies on this linkage are limited. This article views different opinions exist as to whether dynamic capabilities affect organizational effectiveness and performance. (Helfat and Peteraf, 2009) argue that dynamic capabilities do not directly affect organizational effectiveness and performance. They affect organizational effectiveness and performance indirectly by integrating and reconfiguring resources to address the environmental turbulence or to create internal and external change (Eisenhardt and Martin, 2000; López, 2005). Dynamic capabilities create and define the firm's individual resource configuration, which shapes the firm's competitiveness and therefore performance (Galunic and Eisenhardt, 2001). Dynamic capabilities are the key to adoption to the competitive intensity and strive for survival that leads to enhancing the effectiveness of organizational performance (Wilden et al, 2013). Dynamic capabilities positively affect organizational effectiveness and performance in different ways; dynamic capabilities can link the resource base with changing environments (Teece et al., 1997). Create a market change (Eisenhardt and Martin, 2000). Dynamic capabilities improve the effectiveness, speed, and efficiency of organizational responses to environmental requirements and, in turn, essentially support superior performance (Chmielewski and Paladino, 2007). Also, dynamic capabilities i.e. sensing, learning and reconfiguration may can support make

decisions within the organization which has the potential to enhance organizational effectiveness and performance (Eisenhardt and Martin, 2000; Teece, 2007).

(Zollo and Winter, 2002) state that dynamic capabilities enable organizations to acclimate their operating routines constantly to changing environmental turbulence, and allowing them to improve their operating routines performance and survival in competition. Likewise, (Schreyögg and Kliesch-Eberl, 2007) argue that dynamic capabilities may enhance the effectiveness of operating routines by enabling firms to better seize opportunities and overcome threats over their competitors.

Dynamic capabilities may influence organizational effectiveness and performance through employing sensing capability, organizations may detect new and technically significant opportunities, discover the shifts of suppliers and competitors, and identify risks in a timely manner (Wilhelm et al.,2015). By using learning capability, organizations can generate new knowledge; thus, to restore operational capabilities with new knowledge, in turn, achieve better operating-routine goals (Helfat et al,2007). Finally, by employing reconfiguring capability enable organizations to discard, modify, or rebuild in order to adjust their operating routines to new conditions (Teece et al.,1997). In sum, dynamic capabilities contribute to organizational effectiveness through an effective modification of existing operating routines, enabling the organization to adopt environmental changes by way of sensing environmental conditions, learning response patterns and reconfiguring operating routines. Therefore, use dynamic capabilities enhance organizational effectiveness and performance. The impact of dynamic capabilities on organizational effectiveness and performance depends on the organizational context. Both the internal and external contexts are significant in the understanding effect of dynamic capabilities. Internal fit describes the congruent between dynamic capabilities and organizational structure, and external fit, characterized in

matching dynamic capabilities and levels of competitive intensity, represent to fundamental requirements that support the role of dynamic capabilities in affecting organizational effectiveness and performance (Wilden et al.,2013).

Dynamic capabilities are a multidimensional construct of interrelated and complementary dimensions (Barreto, 2010; Teece, 2007). In order to explore in an integrated way, the impact of dynamic capabilities on organizational effectiveness this study determined the dynamic capabilities in three measured dimensions: sensing capability, learning capability, and reconfiguration capability. Sensing capability measures the organization's ability to recognize shifts in the environment to discover opportunities that could impact the organization's business. Learning capability measures the organization's ability to create internal knowledge, to acquire external knowledge, and to assimilate internal and external knowledge through knowledge sharing. Reconfiguration capability measures the organization's ability to create new capabilities, reconfigure assets and organizational structures to address the markets and technologies changes.

4.2.4. Sensing capability and organizational effectiveness

The rapid changes in environment and market, that make the challenge to predict and recognize the paths of future development. New idea, information and knowledge may create opportunities for development. Therefore, sensing capability is firm's ability to constantly scan, search, and explore opportunities across technologies and markets (Teece, 2007). Likewise, (Henderson and Clark, 1990) describe sensing capability as the firm's ability to discover new opportunities, scan environment, respond to competitive strategies and evaluates the competitive position. The firm must have the capability to reconfigure its resource base by sensing the shifts in the environment effectively and respond accordingly that enable the firm to achieve a sustainable competitive advantage (Rehman and Saeed, 2015).

The sensing capability also involves a better understanding of the latent demand, evaluates of industries and markets, and the likely responses of suppliers and competitors. When firms discover a new opportunity, sensing capability not only help firms to understand which technologies should be explored but also enable them to detect which market segments should be targeted (Teece et al.,1997). Sensing capability comprises of three basic processes: First, generates market information, as it relates to the identification of customer needs, respond to marketing trends and identify market opportunities. Second, interpret the gathered market information. Third, responding to market information (Day, 2011; Janssen et al., 2015).

Sensing capability is an initial element of dynamic capabilities, as it is the point where a possible need or opportunity to build, extend or modify existing capabilities are identified based on changes in the internal and external business environment or if the organization can address the changes based on the current capability endowment (Capron and Mitchell, 2009). Sensing, thus, relates to both the firm's capability to recognize changes in the external environment that could affect the organization's business and the ability to identify to what extent the organization might respond with its current capability endowment, or to what extent the development of new capabilities is necessary (Barreto, 2010).

In such way, the sensing capability in educational organizations comprises of external dimensions (environment) and internal dimensions (institution performance) assessment to analytically filter, shape, sense and calibrate the opportunities. Collaboration readiness, learning, and training (analytical skills and individual capacities), performance assessment and environmental assessment also help to capture or sense the opportunity (Labanauske and Nedzinskas,2017). Sensing capability refers to universities' ability to detect opportunities in the internal and external environment (Gratton and Ghoshal, 2005). But, the operational performance such as research and development,

financial and human investment as well as university's ability to scanning, creating and learning are still depend on the university's management to implement the appropriate strategy to coordinate them. Based on the above discussion, the first hypothesis can be derived as follows:

H1: Sensing capability has a significant impact on organizational effectiveness.

4.2.5. Learning capability and organizational effectiveness

Learning capability refers to the firm ability to generate internal knowledge, to acquire external knowledge, and to integrate internal and external knowledge through knowledge sharing (Zahra and George, 2002). The notion of learning is the ability to quickly acquiring or creating specific knowledge necessary to seize the identified opportunities (Eisenhardt and Martin, 2000). To seize opportunities firms need to implement interrelated strategic choices and investment decisions. In order to make significative decisions to address opportunities and threats, it is necessary that firms reach a new state of knowledge in order to understand the alternatives at hand and the interrelatedness of the factors involved (Teece, 2007). Learning capability focuses on the use of market information to generate new knowledge; thus, it is the ability to restore operational capabilities with new knowledge (Kindström et al., 2013). Learning capability refers to the firm's ability to ensure the efficiency and effectiveness of its operational activities by acquiring, changing and reconfiguring resources in cope with environmental changes (Lavie, 2006).

Learning capability composes four basic abilities: first, the ability to acquire knowledge, as it relates to acquiring new knowledge. Second, the ability to realize knowledge as it relates to the clarification of knowledge. Third, the ability to transform knowledge, as it relates to creativity in problem-solving, brainstorming, and creative thinking. Fourth, the ability to use knowledge, as

it relates to the practice of new initiatives and seize opportunities in addition to the renewal of operational capabilities (Li and Liu, 2014; Qiang et al., 2013).

Based on the above contribution, the second hypothesis can be derived as follows:

H2: Learning capability has a significant impact on organizational effectiveness.

4.2.6. Reconfiguration capability and organizational effectiveness

A key to sustaining long-term competitive advantage is it necessary for an organization to recombine and to reconfigure assets and organizational structures to cope with the change of the markets and technologies. Furthermore, to sustain superior firm performance the enterprise has to develop corporate culture, design reward systems and retain committed talent (Teece, 2007). Reconfiguration capability involves activities such redeploying and recombining resources thus, reconfiguration capability enhances continuous development and can also become a mechanism for firms to acquire new resources and seize innovation benefits (Karim and Capron, 2016). Reconfiguration capability refers to the recombination and transformation of existing resources that enable the firm's to address the changes in market conditions (Teece et al., 1997). Reconfiguration capability includes two basic processes: first, create capabilities which can be built internally or can be acquired from external sources. Building capabilities internally relate to the transformation of existing capabilities, i.e. to change the form, shape, or appearance of capabilities existing within the firm (Carlile, 2004). Acquiring capabilities refers to gain capabilities from outside sources, e.g. licensing, purchasing contracts, alliancing, mergers and acquisitions of firms or parts of firm (Capron and Mitchell, 2009; Lavie, 2006). Second, integrate capabilities refers to an engaging, connecting and linking of new capabilities into the

organization with existing resources and capabilities (Iansiti and Clark, 1994; Teece et al., 1997).

Therefore, the reconfiguration capability enables the firm to discard, modify, or rebuild organizational routines and practices in order to make operations more efficient and effective and, in turn, enhance the organizational effectiveness. In such a way, the key to the educational organization's successful effectiveness and performance depends on its ability to demonstrate effective leadership and implement appropriate governance for transformation. Also, the flexibility of business models, reconfigure assets, and routines and organizational structures ensure the superior performance and effectiveness. Based on the above contribution, the third hypothesis can be derived as follows:

H3: Reconfiguration capability has a significant impact on organizational effectiveness.

Considering the above-mentioned hypothesizes, the study proposed the following model as a conceptual model of this paper as it is showing in figure 6.

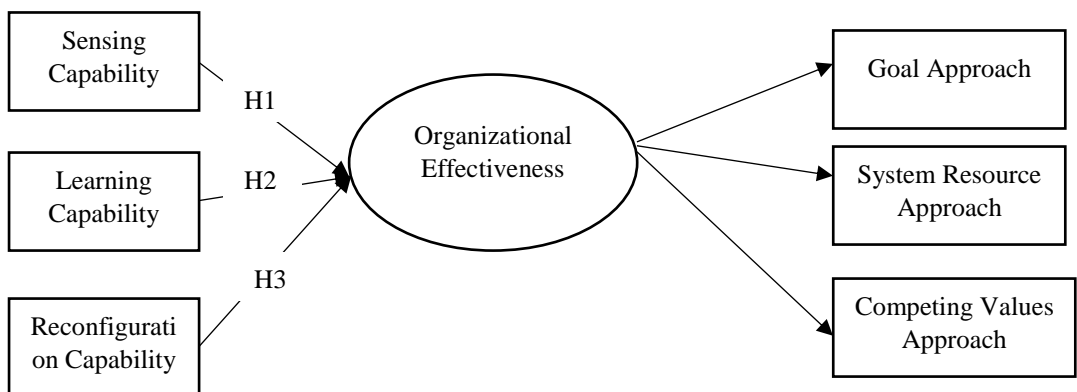

Figure 6. A proposed research model of DC and OE

Source: researcher own construction

4.3. Research Methodology

4.3.1. Research design, sampling and data collection

This research employed a quantitative design. A quantitative design is appropriate to use in hypotheses testing of the relationship between independent and dependent variables (Sekaran and Bougie, 2013). The purpose of this quantitative design study was to examine the impact of dynamic capabilities i.e. sensing capability, learning capability, and reconfiguration capability on organizational effectiveness in the selected Iraqi public universities context. This research used the survey method to collect the primary data because it is considered an economical and efficient method to gather quantitative data concerned to a given population for the purpose of generalizing the result. An online questionnaire was used as a data collation instrument. According to (Grohmann and Kauffeld, 2013) questionnaire is often used while adapting the survey method. The questionnaire was created by the google-forms tool, which is commonly used by researchers for collecting data. The web-based questionnaires were distributed through E-mail designed to collect the relevant data from the public universities of Iraq including a number of deans, heads of departments, faculty members and principals of the execution units which seems to provide a corresponding sample for conducting data collecting and analyzing. The questionnaire was distributed to around 342 employees, out of which 215 completed questionnaires were obtained, with a response rate of 62.86 % of the respondents. The demographic data of the respondents are shown in (table 1 chapter four).

4.3.2. Instrumentation development

The questionnaire comprises of two sections. Section one collects participant and institutional background information of the respondents such as gender, age, the position held, educational attainment, work experience, and organization size. Section two includes items are designed to measure the variables of the study by using a comparative seven-point Likert-type scale

ranging from 1-7, in which, 1 = strongly disagree, 7 = strongly agree. Furthermore, 15 items are designed to measure dynamic capabilities constructs: sensing capability, learning capability, and reconfiguration capability and, 12 items are designed to measure the organizational effectiveness constructs which are goal approach, system resource approach, and competing values approach. Also, Cronbach 's alpha coefficient was used to evaluate the internal consistency of the scales where Cronbach 's alpha coefficient for all the constructs ranges between 0.874 and 0.962 and it is considered acceptable which indicates that all the items are internally consistent. Table (8) shows detailed information regarding the variables, sources, number of the items and Cronbach's alpha as follows:

Table 8. the study measures in regard to the sections of the questionnaire, sources, and Cronbach's alpha

sections	Name of the variable	Source	Number of items	Cronbach's alpha
section one	participant and institutional background information	Researcher developed	9	
Section two	Sensing capability	Teece et al. ,1997);(Eisenhardt and Martin ,2000);(Nievesand Haller,2014)	5	0.924
	Learning capability		5	0.962
	Reconfiguring capability		5	0.938
	Goal approach	(Banat,2002)	4	0.931
	System resource approach	(Abu El Khair, 2016)	4	0.874
	Competing values approach	(Gold et al., 2001), (Rahman et al., 2013)	4	0.936

Source: researcher own construction

4.3.3. Data analysis procedure

Data analysis was conducted to address the research questions, objectives and hypotheses. Statistical Package for Social Science (SPSS) version 23 and the Analysis of Moment Structures (AMOS) software version 24 were used for analyzing data. Before conducting data analysis, the data preparation was done on the completed questionnaires by editing, coding, entering and cleaning the

data. Descriptive statistics such as the frequency and percentage, mean, standard deviation, were used to provided data summarization of demographic characteristics of respondents. Also, the Pearson correlation coefficient was used to describe the correlations among the variables. To purify the instrument items, confirmatory factor analysis (CFA) was carried out to assess the validity and reliability of the instrument by using convergent and discriminant validity. Also, Cronbach's Alpha was used to examine the reliability of the scale items. The overall model fit was assessed using seven goodness-of-fit indices, namely the chi-square/degree of freedom (χ^2/df) ratio, the comparative fit index (CFI), the Tucker-Lewis index (TLI), the goodness of fit index (GFI), the root means square error of approximation (RMSEA). In addition, squares structural equation modeling (SEM) was used to test empirically the proposed hypotheses. SEM is commonly used in the social sciences because of its ability to explain the relationships between unobserved constructs (latent variables) from observable variables (Henson and Roberts, 2006). SEM is comparable to common quantitative methods, such as correlation, multiple regression, and analysis of variance to estimate and test the relationships among constructs.

4.4. Results

4.4.1. Descriptive statistics

Table 9 shows a descriptive analysis (mean and standard deviation) of the data and the correlations matrix among variables. The means score for dynamic capabilities constructs (SC, LC, RC) and organizational effectiveness constructs (GA, SRA, CVA) are located between (3.38-3.80) and standard deviation (1.48-1.62) that indicates a good implementation of dynamic capabilities in enhancement organizational effectiveness in the selected public universities of Iraq. Also, the results show that each of the constructs is positively and significantly correlated to each other.

Table 9. Descriptive and correlation results

	Mean	S. D	SC	LC	RC	GA	SRA	CVA
SC	3.38	1.53	1.000					
LC	3.41	1.54	.891**	1.000				
RC	3.53	1.56	.854**	.867**	1.000			
GA	3.80	1.62	.806**	.843**	.844**	1.000		
SRA	3.44	1.48	.778**	.840**	.818**	.854**	1.000	
CVA	3.80	1.53	.671**	.711**	.719**	.758**	.733**	1.000

** Correlation is significant at the 0.01 level (2-tailed).

SC=Sensing Capability, LC=learning Capability= Reconfiguring Capability, GA=Goal Approach,
SRA=System Resource Approach, CVA=Competing Values Approach

Source: researcher own construction

4.4.2. Reliability and Validity

In this study and before testing the hypotheses reliability and validity of measurement scales were assessed by using confirmatory factor analysis (CFA), employing the statistics program AMOS 24 to estimate the face validity, convergent validity, discriminant validity and goodness of fit statistics. Face validity was established by adopting the scales from the existing literature and adapting them to the current study. The reliability of the scales was evaluated using Cronbach's alpha coefficient. As it is seen in table 8, Cronbach's alpha coefficient for all constructs ranges between 0.874 and 0.953 and it is considered acceptable which indicates that all the items are internally consistent (Hair et al., 2010). In order to determine the convergent validity, there are three important indicators of convergent validity are factor loadings (standardized estimates), Average Variance Extracted (AVE) and Composite Reliability (CR). (Hair et al., 2006) suggests that the items with loadings in between .50 to .70 can be maintained. This study investigates that the item loadings all exceeded the threshold value and statistically significant ($p < 0.05$) (see table 10). Composite reliability (CR) for all constructs ranges between 0.872 and 0.955 which are above 0.50 that indicates that all the constructs have a good level of composite reliability (CR) as recommended by (Hair et al., 2012). The average variance extracted (AVE) value for all the constructs are in the range between .618 to .808 which are above the threshold value .50 which is suggested by (Hair et al., 2010).

Table 10. Constructs evaluation

Constructs	Measurement Items	Factor Loading	CR	AVE	P.Value
Sensing Capability	SC1	0.769	0.767	0.709	.000
	SC2	Deleted			.000
	SC3	0.769			.000
	SC4	0.915			.000
	SC5	0.876			.000
Learning Capability	LC1	0.875	0.899	0.827	.000
	LC2	0.871			.000
	LC3	0.919			.000
	LC4	0.961			.000
	LC5	0.918			.000
Reconfiguration Capability	RC1	0.818	0.837	0.762	.000
	RC2	0.783			.000
	RC3	0.938			.000
	RC4	0.951			.000
	RC5	0.863			.000
Goal Approach	GA4	0.901	0.932	0.789	.000
	GA3	0.837			.000
	GA2	0.904			.000
	GA1	0.91			.000
System Resource Approach	SRA4	0.883	0.872	0.632	.000
	SRA3	0.733			.000
	SRA2	0.722			.000
	SRA1	0.797			.000
Competing Values Approach	CVA4	0.904	0.936	0.772	.000
	CVA3	0.94			.000
	CVA2	0.824			.000
	CVA1	0.841			.000

CR =Composite Reliability and Average, AVE=Variance Extracted

Source: researcher own construction

Discriminant validity was assessed by using two methods: First, (Fornell and Larcker, 1981) method. He suggested that to support for discriminant validity if the square root of the AVE for a latent construct is greater than the correlation values among all the latent variables. Table (11) shows that the

square root of the AVE values of all the constructs is greater than the inter-construct correlations which supports the discriminant validity of the constructs. Second, if AVE for a latent construct is larger than the maximum shared variance with other latent constructs (Hair et al., 2010). Finally, the goodness-of-fit measures were used to assess the fitness of a measurement model. The results, indicate a good model fit to the data (CMIN/df= 1.077, GFI=0.973, TLI= 0.998, CFI=0.999, RMSEA=0.027). Thus, the measurement model indicates a good construct validity and desirable psychometric properties.

Table 11. Discriminant validity of the constructs

	AVE	MSV	SC	LC	RC	GA	SRA	CVA
SC	0.709	0.697	0.842					
LC	0.827	0.807	0.723	0.909				
RC	0.762	0.714	0.801	0.621	0.872			
GA	0.789	0.701	0.721	0.653	0.812	0.880		
SRA	0.632	0.501	0.765	0.541	0.700	0.695	0.795	
CVA	0.772	0.727	0.321	0.652	0.756	0.691	0.609	0.886

Notes: Bold values in diagonal represent the squared root estimate of AVE

AVE= Average Variance Extracted, MSV= Maximum shared variance, SC=Sensing Capability, LC=learning Capability= Reconfiguring Capability, GA=Goal Approach, SRA=System Resource Approach, CVA=Competing Values Approach

4.4.3. Test of hypotheses

The proposed model demonstrates that dynamic capabilities constructs i.e. (sensing capability, learning capability, and reconfiguration capability) have a significant influence on organizational effectiveness. Structured equation modeling (SEM) was used to test this hypothesized model. (Table 12 and figure 7) show the results that (H1) is not supported, that means sensing capability has an insignificant influence on the organizational effectiveness ($\beta=-0.10$, $p<0.0854$). The hypotheses (H2 and H3) are supported. Moreover, the positive significant influence includes, (1) learning capability and

organizational effectiveness ($\beta=0.685$, $p<0.001$) supporting H2; (2) reconfiguration capability and organizational effectiveness ($\beta=0.616$, $p<0.001$) confirmed H3.

Table 12. Result of hypothesis analysis

NO.	Hypotheses	Beta Coefficient	P.Value	Result
H1	Sensing capability → Organizational effectiveness	-0.10	0.854	Not Supported
H2	Learning capability → Organizational effectiveness	0.685	0.001	Supported
H3	Reconfiguration capability → Organizational effectiveness	0.616	0.001	Supported

Source: researcher own construction

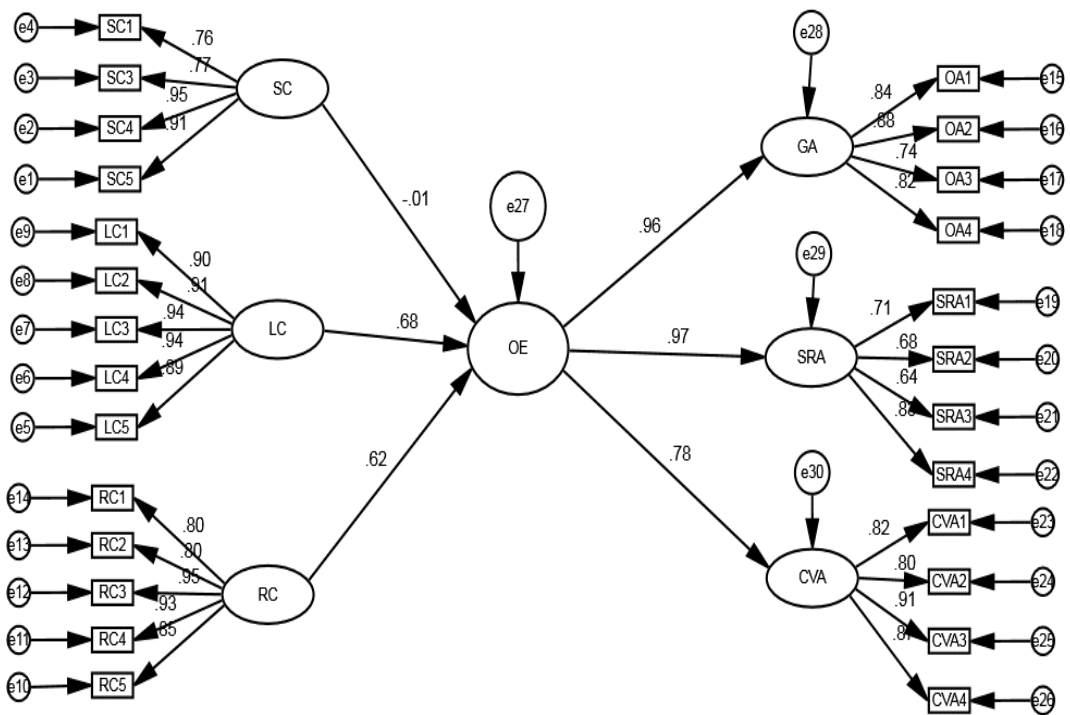

Figure 7. The SEM model analysis of DC and OE

Source: researcher own construction

4.5. Discussion and conclusions

The impact of dynamic capabilities on organizational effectiveness has been an attractive topic among scholars. However, the way that dynamic capabilities

affect organizational effectiveness is still under investigation. Also, the empirical studies on this linkage are limited. The present study provides empirical evidence, which may contribute to filling this gap. The aim of this study is to investigate the influence of dynamic capabilities i.e. (sensing capability, learning capability, and reconfiguration capability) on organizational effectiveness in the Iraqi public universities context. The empirical analysis has shown several key findings: First, analytical results show that sensing capability has no significant impact on organizational effectiveness which means H1 is not supported. The reason underlying this may be that sensing capability impacts indirectly on organizational effectiveness. Second, the analytical results confirmed hypothesis H2 by showing that learning capability significantly affects the organizational effectiveness, which is in line with the suggestions of (Wilhelm et al.,2015) and (Helfat et al,2007). Third, the hypothesis H3 also have similar results showing that reconfiguration capability significantly and positively impacts the organizational effectiveness, which is in line with the opinion of (Teece et al.,1997) and (Eisenhardt and Martin, 2000). In conclusion, the Iraqi public universities can achieve superior organizational effectiveness by using learning capability and reconfiguring capability.

4.5.1. Theoretical contributions of the study

This study tries to address the gap and under-explored issues in the literature in several ways. First, the study contributes to the emerging knowledge on dynamic capabilities and the linkage between the dynamic capabilities and organizational effectiveness. Second, this study attempts to understand and empirically measure two critical managerial and organizational processes. This study determined the dynamic capabilities in three measured dimensions: sensing capability, learning capability, and reconfiguration capability which are explicit constructs. Thus, it shows that dynamic capabilities are not obscure

abstractions that cannot be measured and managed, but specific processes which can be further, theoretically and empirically, explored and, in turn, to understand the nature of dynamic capabilities. Third, the study attempts to empirically test the impact of dynamic capabilities on organizational effectiveness. The findings suggest that sensing capability does not have a positive impact on organizational effectiveness while learning capability and reconfiguration capability have a positive impact on organizational effectiveness. Thus, this study provides a better understanding of the effects of dynamic capabilities.

4.5.2. Managerial implications of the study

In terms of managerial implications, the results of this study provide key implications for managers on how to build and develop dynamic capabilities in order to enhance organizational effectiveness. The results confirm that sensing capability does not have significant effects on organizational effectiveness while learning capability and reconfiguration capability have a significant impact on organizational effectiveness, in this case, managers should focus and put into practice the creation of learning capability and reconfiguration capability instead of sensing capability. For example, managers need to pay attention to how to acquire new knowledge and integrate it into the existing structures through learning capability and how to create new capabilities, rebuild resources and organizational structures to address the environmental turbulence through reconfiguration capability, in turn, universities will be able to achieve superior organizational effectiveness.

4.5.3. Limitations and future research

Despite the significant contributions of this study but, it has some limitations that need to be addressed. First, this study focuses on the selected Iraqi public universities context, which may not be exclusively generalizable to other sectors. Therefore; future research may investigate this phenomenon in other

businesses and economic context. Second, this study adopts a cross-sectional research method for data collection, which does not allow the researcher to examine the causality of the relationships between dynamic capabilities and organizational effectiveness in greater depth. Thus, future research should aim to use longitudinal data to examine the association between dynamic capabilities and organizational effectiveness more accurately. Third, this study examined only three dimensions of dynamic capabilities the future research may include other potential dimensions. Fourth, this study examined the direct effect of dynamic capabilities on organizational effectiveness. Thus, Future research may investigate potential mediating mechanisms into a model of the dynamic capabilities- organizational effectiveness relationship.

CHAPTER- FIVE
MEDIATING ROLE OF DYNAMIC
CAPABILITIES ON THE
RELATIONSHIP BETWEEN HUMAN
RESOURCE DEVELOPMENT AND
ORGANIZATIONAL EFFECTIVENESS

5.1. Introduction

Business environments today, characterized by knowledge-based competition and rapidly changing markets, require organizations use effective strategies to invest and maximize knowledge and skills. Likewise, higher educational organizations undergo intensive transformation processes to address environmental changes. Therefore, a higher educational organization continually attempt to leverage human resource to achieve organizational success. The concept of human resource development (HRD) has emerged as a strategy to develop and improve employee's knowledge, skills, and abilities to enhance organizational effectiveness (Gberevbie, 2012). Developing HRD practices have the potential to improve organizational performance. Some empirical researches have proved that such as (Brockbank, 1999; Garavan, 2007; Clardy, 2008 and Han et al., 2006) emphasis that HRD as a set of responsibilities, competencies, practices, programs, initiatives that have a potential influence on organizational effectiveness. Also, several researchers (McCracken and Wallace.2000; Otoo et al. 2018; Potnuru and Sahoo 2016; Alagaraja et al. 2015; and Nilsson and Ellstrom 2012) established that there is a significant relationship between human resource development and organizational effectiveness. Nevertheless, in rapidly changing environments organizations must be prepared for change and have the human capital to meet and cope with the environmental turbulence. HRD plays a key role to maintain and develop human resources in accordance with the changing direction of corporate goals and objectives (Shanahan et al. 2012). Hence, in such an environment, superior organizational effectiveness based on organizations ability to integrate, build, and reconfigure internal and external resource to address environmental changes, the process of which is termed as dynamic capabilities. Dynamic capabilities contribute to organizational effectiveness through an effective modification of existing operating routines, enabling the organization to adopt environmental changes by way of sensing environmental

conditions, learning response patterns and reconfiguring operating routines. (Teece et al.,1997). Furthermore, many strategic management researchers (Lado and Wilson 1994; Lepak and Snell 1999; Wright et al. 2001) argue that dynamic capabilities can enhance and sustain organizational effectiveness over time when they are developed with complementary human resource development practices. Despite this progress, there is still a lack in the literature about an understanding of the mediating mechanisms of dynamic capabilities on the relationship between HRD practices and organizational effectiveness. More recently, studies such as (Wang et al. 2012; Wilhelm et al.,2015; and Helfat et al.,2007) focus on how developing dynamic capabilities by human resource. Based on the knowledge of the authors there were no studied investigated the alternative relationships except Lopez-Cabrales et al. (2017) investigate the relationship between dynamic capabilities and HRM considering the mediating role of leadership styles. The importance of developing dynamic capabilities for the universities has been demonstrated to create more ideas and capture more licensing value, enhance value creation and commercialization, and develop an institutional environment at the subnational level (Bejinaru,2017). The achievement of dynamic capabilities requires the support of strategic HRD practices through human expertise development with the core values of universities (Hamadamin and Atan, 2019). Hence, the purpose of this study is to investigate the mediating role of dynamic capabilities on the relationship between human resource development and organizational effectiveness in the selected public universities context. Consequently, this study tries to address this gap by proposing an empirical model that demonstrates dynamic capabilities constructs i.e. sensing capabilities, learning capabilities and reconfirmation capabilities mediate the relationship between HRD constructs i.e. talent development, training and development, organizational development, and career development and organizational effectiveness. In addition to, this study is novel which tries to

meet the need of the higher education sector in Iraq to such studies, for its influential role in society.

The remainder of the article is organized as follows: the first section presents the introduction. The second section describes the literature review. The third section presents the research methodology. The fourth section shows the data analysis and results. The last section presents a discussion of the findings including theoretical and practical implications, study limitations and future research.

5.1.2. Research questions

According to the discussion above, the following questions guided the study design:

1. Do HRD practices influence organizational effectiveness?
2. Do HRD practices influence dynamic capabilities?
3. Do dynamic capabilities influence organizational effectiveness?
4. Do dynamic capabilities mediate the relationship between HRD practices and organizational effectiveness?

5.3. Literature review and hypotheses development

5.3.1. Human resource development contributions to organizational effectiveness and dynamic capabilities

This study argues that HRD practices have a direct impact on organizational effectiveness regardless of environmental changes. Several researchers such as (Mohammed 2006; Alagaraja et al., 2015; and Potnuru and Sahoo 2016) have discussed this issue. Mohammed (2006) argues that the success and progress of an organization lie in its ability to explore and attract the talent and potentials of its workforce, and this is can be achieved through the HRD practices. Riordan et al. (2005) argue that appropriate, ongoing training and development and career development enable employees to develop the skills, abilities, and

knowledge required for effective performance, in turn, improve organizational effectiveness. Likewise, Adhikari (2010) indicates that HRD supports and strengthening of an organization's human capital base by increasing the level of knowledge, skills, and capabilities of individuals in an organization and thus contributes to improved performance and competitive advantage. Potnuru and Sahoo (2016) argue that HRD practices training, career development, and performance management have an impact on the building of employee competencies which, in turn, enhance organizational effectiveness. Agwu and Ogiriki (2014) argue that use of HRD practices training and development, organizational development and career development lead to improving organizational effectiveness through improvement in individual, group knowledge, skills, attitudes, and behavior. Otoo et al. (2019) argue that HRD practices such as performance appraisal, career development, and training and development have a significant impact on organizational effectiveness through their impact on employee performance. Similarly, Swanson and Holton (2009) emphasize that HRD practices improve employee competence, in turn, enhance organizational effectiveness.

Alagaraja et al. (2015) state that there are five significant approaches for investigating the linkage of HRD and organizational performance and effectiveness: First, the best-fit approach which is an emphasis that HRD practices must convenient the characteristics of the organization. Second, the best-practice approach suggests HRD practices have a positive influence on performance and these practices can be adopted by other organizations for improving performance. Third, a combination of a best-fit approach and best-practice approach suggests that HRD contributions to the organizational effectiveness and performance through the combining of both the approaches. Fourth, the stake holder's perception approach indicates that investigating the impact HRD on organizational effectiveness and performance through the

contribution of stakeholder perceptions. Fifth, focus on the aforementioned approaches.

Nevertheless, in the rapidly changing environment, the organizations need to address environmental shifts and changes through developing so-called dynamic capabilities. This study states that HRD practices have a significant impact on building dynamic capabilities. However, the relationship between HRD and dynamic capabilities is still under developing (Wright and Snell, 2009). Only a few studies address the linkage between HRD and dynamic capabilities (Teece et al., 1997; Eisenhardt and Martin, 2000; Zahra and George, 2002; Teece, 2007; Hsu and Wang, 2012) have confirmed that learning, sensing, integrating, and reconfiguration capabilities of the organization are highly lie on employee's knowledge, skills, abilities and experienced these are the outcome of human resources development practices. Likewise, Garavan et al. (2016) argue that HRD practices help employees to work effectively in different environmental conditions and improve knowledge, skill, behavioral, and attitudinal outcomes that provide employees with the flexibility to respond to shifts in the environment. When organizations use human resource development practices to develop and leverage human capital, in turn, may catch the benefits of complementarities and co-specialization to develop dynamic capabilities (Barney 1991; Grant 1996). Human resource development practices such as training and development performance evaluation and compensation systems have the potential to enhance the dynamic capability and maintain the sustainable competitive advantage of organizations (Yan and Gao,2016). In changing environmental conditions HRD practices can increase the flexible organization, organizational learning, resources integration, and environmental perception (Chengcheng,2010). Teece et al. (1997) define dynamic capabilities as the firm's ability to integrate, build, and reconfigure internal and external competencies to address rapidly changing environments. Garavan (2007)

argues that HRD supports the development of dynamic capabilities that are critical in developing and maintaining a sustained competitive advantage.

This study argues that HRD practices have a direct impact on dynamic capabilities. In order to explore in an integrated way, the linkage between HRD and dynamic capabilities, this study determined the dynamic capabilities in three measured dimensions: sensing capability, learning capability, and reconfiguration capability. Sensing capability is the firm's ability constantly to discover, explore and interpret opportunities in the environment (Pavlou and El Sawy 2011). Therefore, HRD helps organizations to make sense of shifts in the environment, set plans, and seize opportunities (Garavan et al.,2016). Eisenhardt and Martin (2000) state that learning capability is the firm ability's acquiring or creating specific knowledge necessary to seize the identified opportunities. HRD practices improve learning mechanisms such as experience accumulation, knowledge creation, and sharing knowledge are critical to the formation of learning capability (Zollo and Winter, 2002). Reconfiguration capability refers to the recombination and transformation of existing resources that enable firms to address the changes in market conditions (Teece, 2007). HRD enhances the creation of new capabilities, configure assets and organizational development to address the markets and technologies changes.

This study contributes to the theory and research on human resource development contribution to organizational effectiveness and dynamic capabilities by examining the direct impact of HRD practices on organizational effectiveness and dynamic capabilities. Based on the aforementioned contributions, this study hypothesizes

H1: HRD practices have a significant impact on organizational effectiveness.

H2: HRD practices have a significant impact on dynamic capabilities.

5.3.2. Dynamic capabilities and organizational effectiveness

The dynamic capabilities concept has emerged due to the changes in environments and market. Scholars (Hammer, 2001 and Zott, 2003) have stated that to sustain a competitive advantage in a rapidly changing environment, organizations need to develop dynamic capabilities for improving core competencies and enhance organizational effectiveness. This study argues that dynamic capabilities have a significant potential on organizational effectiveness. But, the association between dynamic capabilities and organizational effectiveness and performance is still unclear (Zhou and Zhou, 2017). However, some scholars (Teece et al. 1997; Eisenhardt and Martin, 2000; López, 2005 and Wilden et al, 2013) argue that dynamic capabilities enable organizations to link the resource base with environmental shifts, create market change, and facilitate resource access and resource development, in turn, enhance the organizational effectiveness. Teece (2007) argues that dynamic capabilities enable an organization to achieve competitive advantage in a changing business environment through developing specific capabilities and competencies which support organizational effectiveness and performance. Fainshmidt et al. (2016) argue that dynamic capabilities are significantly related to organizational effectiveness. The scholars (Rehman and Saeed, 2015; Takahashi et al.,2016 and Zhou and Zhou,2017) emphasize that dynamic capabilities have an indirect impact on the organizational effectiveness through mediated by the development of operational capabilities. Based on the above discussion, the third hypothesis can be derived as follows: *H3: Dynamic capabilities have a significant impact on organizational effectiveness.*

5.3.3. Human resource development, dynamic capabilities, and organizational effectiveness

The aforementioned literature has established that HRD practices significantly influence organizational effectiveness. But, in rapidly changing environments,

HRD is often not enough to support organizational effectiveness (Teece et al., 1997 and Aminu and Mahmood,2015). Thus, this study, argues that in such dynamic environment HRD practices have potential to influence organizational effectiveness indirectly through mediating of dynamic capabilities. Moreover, due to rapidly changing in the environment, the organizations should prepare for the change to address the shifts in the environment and cope with markets conditions. The organizations strive to develop capabilities to integrate, build, and reconfigure internal and external competencies to address rapidly changing environments, in return, support make decisions within the organization which has the potential to enhance organizational effectiveness and performance (Eisenhardt and Martin, 2000; Teece, 2007). HRD plays a key role to maintain and develop human resources in accordance with the changing direction of corporate goals and objectives(Shanahan et al. 2012). HRD contributes to the creation of new capabilities and the renewal and reconfigures of existing capabilities to cope with dynamic environments (Zollo and Winter 2002). Therefore, it is significant to study the mediating role of dynamic capabilities in the relationship between HRD and organizational effectiveness. However, due to limited studies in the literature, there is still confusion about how dynamic capabilities mediate the relationship between HRD and organizational effectiveness. Even though, there are few researchers (Lado and Wilson 1994, Tseng and Lee, 2014; Aminu and Mahmood,2015; and Garavan et al, 2016) investigated this issue. Furthermore, (Lado and Wilson 1994; Wright et al. 2001) argue that dynamic capabilities can ensure sustainable organizational effectiveness when they are developed through HRD practices. Similarly, Garavan et al. (2016) argue that HRD practices, structures, and processes can, develop unique dynamic capabilities that enhance the organizational effectiveness in the environmental turbulence. Wang et al. (2012) argue that to maintaining dynamic capabilities requires organizations to develop the

human resources that enable them to improve the organizational effectiveness and preference and in correspondence with the dynamic environment. As such, the present study hypothesized that dynamic capabilities mediate the relationship between human resources development practices and organizational effectiveness. The hypothesis is presented as follows:

H4: Dynamic capabilities significantly mediate the relationship between human resources development practices and organizational effectiveness.

Considering the above-mentioned hypothesizes, the study proposed the following model as a conceptual model of this paper (Figure 8).

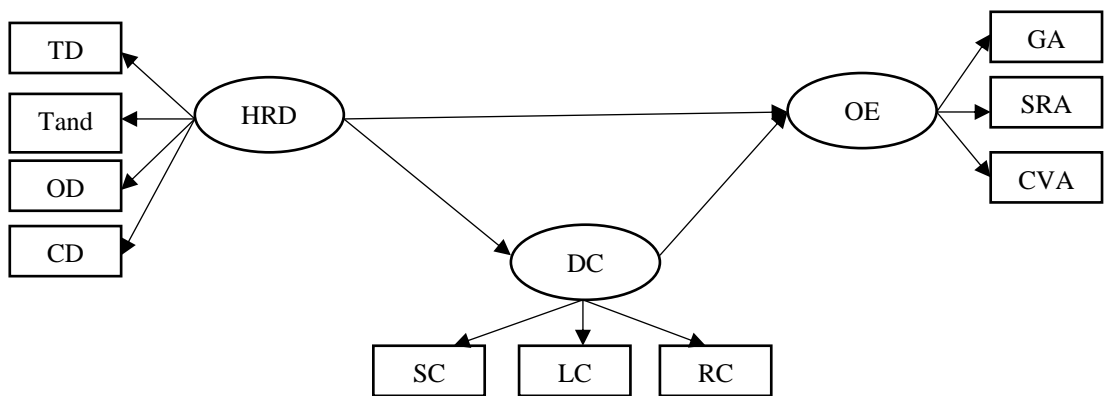

Figure.8 Conceptual model of HRD, DC and OE

HRD=Human Resource Development, DC=Dynamic Capabilities, OE=Organizational Effectiveness, TD=Talent Development, TandD=Training and Development, OD=Organizational Development, CD=Career Development SC=Sensing Capability, LC=learning Capability= Reconfiguring Capability, GA=Goal Approach, SRA=System Resource Approach, CVA=Competing Values Approach.

Source: researcher own construction

5.4. Research methodology

5.4.1. Research design, sampling and data collection

To test the proposed model, this research employed a deductive approach based on a quantitative method. The purpose of this quantitative method is to examine the mediating role of dynamic capabilities on the relationship between human resource development and organizational effectiveness. According to Sekaran and Bougie (2013), the quantitative method is appropriate to use in

hypotheses testing of the relationship between independent and dependent variables. This study took place in top ten Iraqi public universities. For collecting the primary data this research used the survey method because it is considered an economical and efficient method to gather quantitative data concerned to a given population for the purpose of generalizing the result. This study employed a web-based survey for collecting data from the universities. An online questionnaire was developed based on the literature (see table 16 and appendix 1) to collect the primary data. The questionnaire was created by the google-forms tool, which is commonly used by researchers for collecting data. The web-based questionnaires were distributed through e-mail designed to collect the primary data from the selected universities . The sample is including a number of deans, heads of departments, faculty members, principals, and administrative staff which seems to provide a corresponding sample for conducting data collecting and analyzing. The questionnaire was distributed to around 342 employees, out of which 215 completed questionnaires were obtained, with a response rate of 62.86 % of the respondents. The demographic data of the respondents are shown in (table 1chapter four).

5.4.2. Data analysis procedure

Data analysis was conducted to address the research questions, objectives and hypotheses. Statistical Package for Social Science (SPSS) version 23 and the Analysis of Moment Structures (AMOS) software version 24 were used for analyzing data. Before conducting data analysis, the data preparation was done on the completed questionnaires by editing, coding, entering and cleaning the data. Descriptive statistics such as the frequency and percentage, mean, standard deviation, were used to provided data summarization of demographic characteristics of respondents. Also, the Pearson correlation coefficient was used to describe the correlations among the variables. Confirmatory factor

analysis (CFA) was carried out to assess the validity of the measurement model, fitting and modification. Also, Cronbach's Alpha was used to examine the reliability of the scale items. The overall model fit was assessed using five goodness-of-fit indices, namely the chi-square/degree of freedom (χ^2/df) ratio, the comparative fit index (CFI), the Tucker-Lewis index (TLI), the goodness of fit index (GFI), the root means square error of approximation (RMSEA). In addition, squares structural equation modeling (SEM) was used to test empirically the proposed hypotheses. SEM is commonly used in the social sciences because of its ability to explain the relationships between unobserved constructs (latent variables) from observable variables (Henson and Roberts, 2006). SEM is comparable to common quantitative methods, such as correlation, multiple regression, and analysis of variance to estimate and test the relationships among constructs.

5.4.3. Instrumentation development and measures

The questionnaire was developed based on an extensive review of the literature related to the topic of the study. The questionnaire comprises of two sections. Section one collects participant and institutional background information of the respondents such as age, gender, a position held, educational attainment, work experience, and organization size. Section two includes questions are designed to measure the variables of the study by using a comparative seven-point Likert-type scale ranging from 1-7, in which (1 = strongly disagree, 7 = strongly agree). The variables used in this study were assessed using multiple items from different studies in the extant literature.

Human resource development: was operationalized as a four-dimensional construct: talent development, training and development, organizational development, and career development. 20 items are designed to measure HRD constructs by employing five items for each construct respectively, these items

were adopted from (Mahfoozi et al.,2018; Asfaw et al.2015; Spirina,2015; Zadeha and Ghahremanib,2016; Xueling,2017; and Weng and McElroy,2012). *Dynamic capabilities*: dynamic capability was operationalized by three dimensions: sensing capability, learning capability, integrating capability. 15 items are designed to measure dynamic capabilities constructs by employing five items for each construct respectively. The items were adapted from (Teece et al. ,1997; Eisenhardt and Martin, 2000; and Nieves and Haller,2014). *Organizational effectiveness*: was measured by three approaches: goal approach, system resource approach, and competing values approach. 12 items were used to measure organizational effectiveness by employing four items for each construct respectively. The items were adapted from (Gold et al., 2001; Rahman et al., 2013; Banat, 2002; and Abu el Khair,2016). Also, Cronbach ‘s alpha coefficient was used to evaluate the internal consistency of the scales where Cronbach ‘s alpha coefficient for all the constructs ranges between 0.874 and 0.962 and it is considered acceptable which indicates that all the items are internally consistent. Table (13) shows detailed information regarding the variables, sources, number of the items and Cronbach’s alpha.

Table 13. The study measures in regard to the variables, sources, and Cronbach’s alpha

variables		Source	Number of items	Cronbach’s alpha
Human Resource Development	Talent development	(Mahfoozi et al.,2018)	5	0.946
	Training and development	(Asfaw et al.2015)	5	0.932
	Organizational development	(Rastgoo, 2016) and (Zadeha and Ghahremanib, 2016)	5	0.947
	Career development	(Weng and McElroy, 2012) and (Xueling, 2017)	5	0.953
Dynamic Capabilities	Sensing capability	Teece et al. ,1997);(Eisenhardt and Martin ,2000);(Nievesand Haller,2014)	5	0.924
	Learning capability		5	0.962

	Reconfiguring capability		5	0.938
Organizational Effectiveness	Goal approach	(Banat,2002)	4	0.931
	System resource approach	(Abu El Khair, 2016)	4	0.874
	Competing values approach	(Gold et al., 2001),(Rahman et al., 2013)	4	0.936

Source: researcher own construction

5.5. Results

5.5.1. Descriptive statistics

Table 14 shows a descriptive analysis (mean and standard deviation) of the data and the correlations matrix among variables. The means score for all the constructs is located between (3.29-3.80) and standard deviation (1.48-1.62) that indicates a good implementation of HRD practices and dynamic capabilities in enhancement organizational effectiveness in the selected public universities of Iraq. Also, the results show that each of the constructs is positively and significantly correlated with each other.

Table 14. Descriptive and correlation results

	Me an	S. D	T D	Ta n D	OD	CD	SC	LC	RC	GA	SR A	CV A	HR D	DC s	OE
TD	3.2 9	1.59	1.0												
Tan dD	3.4 9	1.56	.77 **	1.0											
OD	3.4 6	1.60	.77 **	.82 **	1.0										
CD	3.3 5	1.59	.75 **	.79 **	.83 **	1.0									
SC	3.3 8	1.53	.79 **	.79 **	.84 **	.80 **	1.0								
LC	3.4 1	1.54	.80 **	.81 **	.86 **	.84 **	.88 **	1.0							
RC	3.5 3	1.56	.77 **	.81 **	.84 **	.79 **	.84 **	.86 **	1.0						
GA	3.8 0	1.62	.73 **	.83 **	.85 **	.78 **	.80 **	.84 **	.84 **	1.0					

SRA	3.4 4	1.48	.70 **	.79 **	.76 **	.71 **	.77 **	.85 **	.82 **	.85 **	1.0				
CV A	3.8 0	1.53	.62 **	.69 **	.70 **	.69 **	.67 **	.72 **	.73 **	.77 **	.74 **	1.0			
HR D	3.3 9	1.58	.90 **	.92 **	.93 **	.92 **	.87 **	.90 **	.87 **	.87 **	.80 **	.74**	1.0		
DCs	3.4 4	1.54	.82 **	.84 **	.88 **	.85 **	.95 **	.96 **	.94 **	.87 **	.85 **	.74**	.92**	1.0	
OE	3.6 8	1.54	.73 **	.83 **	.83 **	.79 **	.80 **	.87 **	.86 **	.94 **	.93 **	.90**	.87**	.88 **	1.0

** Correlation is significant at the 0.01 level (2-tailed).

HRD=Human Resource Development, DCs=Dynamic Capabilities, OE=Organizational Effectiveness, TD=Talent Development, T&D=Training and Development, OD=Organizational Development, CD=Career Development SC=Sensing Capability, LC=learning Capability= Reconfiguring Capability, GA=Goal Approach, SRA=System Resource Approach, CVA=Competing Values Approach. Measurement Items used for calculation of the listed variables are explained in Appendix 1.

5.5.2. Measurement model

To assess the validity of the measurement model and to test the fitting of the data with the proposed model confirmatory factor analysis (CFA) was used to assess the fitness of a measurement model. This study used some indexes like CMIN/df, GFI, TLI, CFI, and RMSEA to investigate the goodness of fit of the model. Table 15 presents the results of the index of confirmatory factor analysis. The results indicate that the goodness-of-fit indicators of all three models are satisfied with the suggested threshold value by (Jacob et al., 2003) thus, indicated good model fitness.

Table 15. Index of confirmatory factor analysis

	HRD model	DC model	OE model
CMIN/df	1.895	1.547	1.828
GFI	0.874	0.883	0.900
TLI	0.931	0.970	0.955
CFI	0.944	0.978	0.973
RMSEA	0.0721	0.073	0.070

Source: researcher own construction

5.5.3. Reliability and validity

In this study and before testing the hypotheses reliability and validity of measurement scales were assessed by using confirmatory factor analysis

(CFA), and AMOS 24 was used to estimate convergent validity and discriminant validity. The reliability of the scales was evaluated using Cronbach's alpha coefficient as it is seen in table 13, Cronbach's alpha coefficient for all constructs ranges between 0.874 and 0.962 and it is considered acceptable which indicates that all the items are internally consistent (Hair et al., 2010). In order to determine the convergent validity, there are three important indicators of convergent validity which are factor loadings (standardized estimates), Average Variance Extracted (AVE) and Composite Reliability (CR). Hair et al. (2006) suggests that the items with loadings in between .50 to .70 can be maintained. This study investigates that the item loadings all exceeded the threshold value and statistically significant ($p < 0.05$) (see table 16). Composite reliability (CR) for all constructs ranges between 0.767 and 0.955 which are above 0.50 that indicates that all the constructs have a good level of composite reliability (CR) as recommended by (Hair et al., 2012). The average variance extracted (AVE) value for all the constructs are in the range between .632 to .827 which are above the threshold value .50 which is suggested by (Hair et al., 2010).

Table 16. Constructs evaluation

Constructs	Measurement Items	Factor Loading	CR	AVE	P.Value
Talent Development	TD5	0.852	0.947	0.780	.000
	TD4	0.884			.000
	TD3	0.896			.000
	TD2	0.898			.000
	TD1	0.852			.000
Training and development	T_D5	0.807	0.932	0.732	.000
	T_D4	0.902			.000
	T_D3	0.886			.000
	T_D2	0.855			.000
	T_D1	0.827			.000
Organizational Development	OD5	0.900	0.948	0.785	.000
	OD4	0.900			.000
	OD3	0.904			.000
	OD2	0.875			.000
	OD1	0.850			.000

Career Development	CD5	0.854	0.955	0.808	.000
	CD4	0.952			.000
	CD3	0.904			.000
	CD2	0.922			.000
	CD1	0.861			.000
Sensing Capability	SC1	0.769	0.767	0.709	.000
	SC2	Deleted			.000
	SC3	0.769			.000
	SC4	0.915			.000
	SC5	0.876			.000
Learning Capability	LC1	0.875	0.899	0.827	.000
	LC2	0.871			.000
	LC3	0.919			.000
	LC4	0.961			.000
	LC5	0.918			.000
Reconfiguration Capability	RC1	0.818	0.837	0.762	.000
	RC2	0.783			.000
	RC3	0.938			.000
	RC4	0.951			.000
	RC5	0.863			.000
Goal Approach	GA4	0.901	0.932	0.789	.000
	GA3	0.837			.000
	GA2	0.904			.000
	GA1	0.910			.000
System Resource Approach	SRA4	0.883	0.872	0.632	.000
	SRA3	0.733			.000
	SRA2	0.722			.000
	SRA1	0.797			.000
Competing Values Approach	CVA4	0.904	0.936	0.772	.000
	CVA3	0.940			.000
	CVA2	0.824			.000
	CVA1	0.841			.000

CR =Composite Reliability and Average, AVE=Variance Extracted
Source: researcher own construction

Discriminant validity was assessed by using two methods: First, (Fornell and Larcker, 1981) method. He suggested that to support for discriminant validity if the square root of the AVE for a latent construct is greater than the correlation values among all the latent variables. Table (17) shows that the square root of the AVE values of all the constructs is greater than the inter-construct correlations which supports the discriminant validity of the constructs. Second, (Hair et al., 2010) he suggests if AVE for a latent construct is larger than the maximum shared variance with other latent constructs that

indicates discriminant validity can be maintained. Thus, the measurement model indicates a good construct validity and desirable psychometric properties.

Table 17. Discriminant validity of the constructs

	AVE	MSV	TD	T_D	OD	CD	SC	LC	RC	GA	SRA	CVA
TD	0.780	0.682	0.883									
T_D	0.732	0.706	0.823	0.855								
OD	0.785	0.749	0.816	0.817	0.886							
CD	0.808	0.664	0.785	0.827	0.866	0.898						
SC	0.709	0.697	0.532	0.721	0.781	0.421	0.842					
LC	0.827	0.807	0.621	0.608	0.801	0.305	0.723	0.909				
RC	0.762	0.714	0.712	0.512	0.601	0.541	0.801	0.621	0.872			
GA	0.789	0.701	0.798	0.836	0.821	0.850	0.721	0.653	0.812	0.888		
SRA	0.632	0.501	0.788	0.648	0.771	0.708	0.765	0.541	0.700	0.695	0.795	
CVA	0.772	0.727	0.068	0.744	0.754	0.737	0.321	0.652	0.756	0.691	0.609	0.886

Notes: Bold values in diagonal represent the squared root estimate of AVE

AVE= Average Variance Extracted, MSV= Maximum shared variance

Source: researcher own construction

5.5.4. Common method bias checks

Due to this research is employed a cross-sectional with a self-report questionnaire, common method variance (CMV) may affect systematic measurement accuracy (Podsakoff and Organ, 1986). Harman's single-factor test was used to address this issue by using exploratory factor analysis (EFA). The results show that the total variance for a single factor is less than 50% which means that common method bias does not confound the interpretations of the results.

5.5.5. The structural model: test of hypotheses

5.5.5.1. The direct effects

Structured equation modeling (SEM) was used to test the hypothesized model. The results of the proposed structural model show the good fit (CMIN/df= 1.418, GFI=0.925, TLI= 0.986, CFI=0.990, RMSEA=0.064). In order to verify the following hypotheses, H1, H2, H3 direct effects were assessed. The results, presented in (Figure 9 and Table 18) indicate that the three hypotheses are

supported. In particular, HRD practices have a significant impact on organizational effectiveness ($\beta=0.390$, $p<0.001$) supporting H1. Similarly, the results revealed that HRD practices have a significant impact on the dynamic capabilities ($\beta=0.982$, $p<0.001$), therefore the hypothesis H2 is supported. Also, the results confirmed that dynamic capabilities significantly influence organizational effectiveness ($\beta=0.568$, $p<0.001$) which is supporting the hypothesis H3.

Table 18. Results of direct effects

NO.	Hypotheses path	Beta Coefficient	P. Value	Result
H1	HRD→OE	0.390	0.001	Supported
H2	HRD → DC	0.982	0.001	Supported
H3	DC→ OE	0.568	0.001	Supported

Source: researcher own construction

5.5.5.2. The mediating effects

In order to test hypothesis H4 indirect effect was assessed. The results showed in table 19 indicate that dynamic capabilities are significantly mediate the relationship between HRD practices and organizational effectiveness ($\beta=0.558$, $p<0.001$). Also, the bootstrapping was used in order to calculate the 95% confidence interval of the indirect. The results show there is no zero between lower and upper limits which is provided evidence that hypothesis H4 is supported.

Table 19. Results of mediating effect

NO.	Hypotheses path	Beta Coefficient	P. Value	95%LL	95%UL	Result
H4	HRD→ DC→ OE	0.558	0.001	0.073	0.533	Supported

A hypothesis is supported, when there is no zero between lower and upper limits, LL: Lower limit, UL: Upper limit. Source: researcher own construction

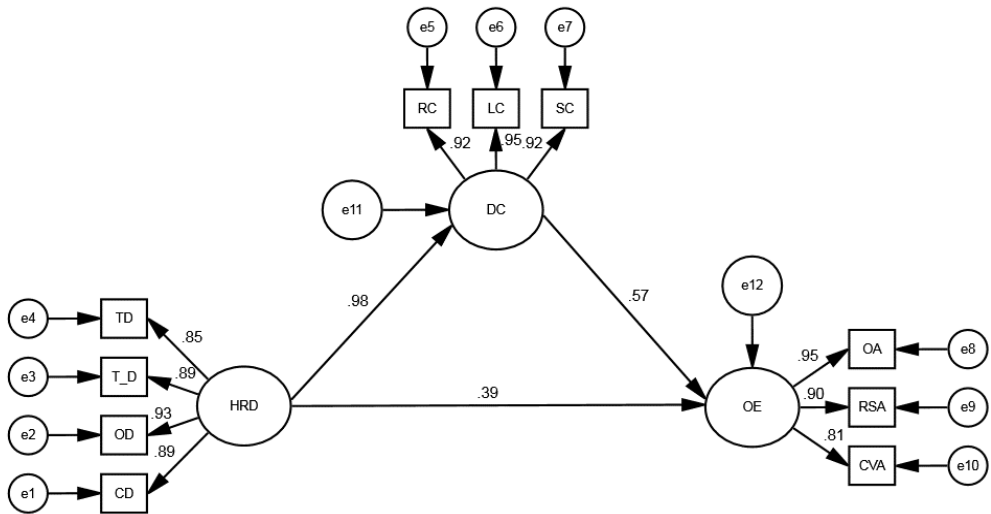

Figure 9. The SEM model analysis of HRD, DC, and OE
Source: researcher own construction

5.6. Discussion and conclusions

Due to limited studies in the literature, there is still confusion about how the impact of HRD practices on organizational effectiveness through the mechanisms of dynamic capabilities. The aim of this study is to investigate the mediating role of dynamic capabilities in the relationship between HRD practices and organizational effectiveness in the selected Iraqi public universities context. This study proposed a causal model that explains the relationship between HRD practices and organizational effectiveness through the role played by dynamic capabilities. The present study found out four key findings. First, HRD practices significantly influence organizational effectiveness which is in line with the suggestions of (Mohammed 2006; Alagaraja et al., 2015; and Potnuru and Sahoo 2016). Second, HRD practices have a significant impact on dynamic capabilities which is in line with the opinions of (Garavan et al., 2016; Yan and Gao, 2016 and Teece, 2007). Third, dynamic capabilities significantly influence organizational effectiveness which is consistent with (Zhou, 2017; Fainshmidt et al., 2016 and Teece et al., 1997). Fourth, dynamic capabilities significantly mediate the relationship

between HRD practices and organizational effectiveness which is in line with the opinions (Zollo and Winter 2002; Aminu and Mahmood, 2015). In conclusion, this study argues that the relationship between HRD practices and organizational effectiveness is not direct in changing business environments but through the mediating role of dynamic capabilities. Consequently, in such shifts and turbulences in business environments, organizations need to develop not only a human resource but also dynamic capabilities for sensing environmental conditions, learning response patterns and reconfiguring operating routines, in turn, organizations will be able to achieve superior organizational effectiveness.

5.6.1. Theoretical contributions of the study

Regarding the theoretical contribution, this study provides a research model for empirical literature in the field of human resource devolvement, dynamic capabilities, and organizational effectiveness. Specifically, this study developed a model to investigate the direct relationship between HRD and organizational effectiveness and dynamic capabilities and the relationship between dynamic capabilities and organizational effectiveness as well as to examine the mediating role of dynamic capabilities on the relationship between HRD and organizational effectiveness. The results from a structural equation modeling approach have confirmed all the hypothesized relations. The results show that HRD practices significantly impact on organizational effectiveness and dynamic capabilities. The study shows that dynamic capabilities have a positive impact on organizational effectiveness. Also, the study empirically supports the mediating effect of dynamic capabilities on the relationship between HRD practices and organizational effectiveness. Despite of, that HRD, dynamic capabilities and organizational effectiveness have attracted considerable attention in the literature but, only very limited studies have highlighted the mediating role of HRD capabilities in the relationships between

HRD and organizational effectiveness. Therefore, the empirical findings of this study have potential significance to fill the gap in the literature.

5.6.2. Managerial implications of the study

Besides the theoretical implications, this study provides practical implications for universities management, the present study provides significant insight and demonstrates a good understanding of HRD practices, dynamic capabilities and organizational effectiveness in the selected Iraqi public universities context. The findings of this study have the potential to help decision-makers to design their HRD practices to contribute to enhance organizational effectiveness. The study brings universities management closer to understand the role of dynamic capabilities to integrate, build, and reconfigure internal and external competencies to address rapidly changing environments, in turn, support make decisions within the organization which has the potential to enhance organizational effectiveness and performance. In such an environment, universities management should develop not only HRD practices but, also adopt dynamic capabilities mechanisms to improve organizational effectiveness.

5.6.3. Limitations and future research

Despite of the theoretical and managerial contributions, this study has some limitations that need to be addressed in future research. First, this study focuses on the top ten Iraqi public universities context, which may not be exclusively generalizable to other sectors. Therefore; future research may investigate this phenomenon in other businesses and economic context. Second, the sample of the study somewhat is small because of the unsafe situation in Iraq the authors couldn't get an appropriate sample. However, future research may conduct in big enough and appropriate sample. Third, this study adopts a cross-sectional research method for data collection, which does not allow the researcher to examine the causality of the relationships between the variables in greater

depth. Thus, future research should aim to use longitudinal data which could explain the highlighted relationships more insights. Fourth, this study focuses on four dimensions of HRD, three dimensions of dynamic capabilities and three dimensions of organizational effectiveness. therefore, future research may include other potential dimensions. The findings of this study are limited to the selected Iraqi public universities context and cannot be generalized to other countries and other businesses context.

CHAPTER – SIX
DISCUSSION AND CONCLUSIONS

6.1. Overall discussion and conclusions

The study sought to increase the understanding the impact of human resource development on organizational effectiveness and explores the mediating role of dynamic capabilities on the relationship between human resource development and organizational effectiveness in the Iraqi public universities context. This dissertation reveals important empirical results that make a significant contribution to address the research questions and hypotheses. To do so, this dissertation conducted three empirical studies. The first study is presented in chapter four which investigates the impact of human resource development practices i.e. talent development, training and development, organizational development, and career development. The results confirmed that all HRD practices have a significant positive impact on organizational effectiveness and thus all the hypotheses are supported. The findings of this study are in line with the suggestions of (Otoo and Mishra, 2018; Potnuru and Sahoo, 2016; Alagaraja et al.,2015; Nilsson and Ellstrom,2012). This study concludes that all the HRD practices are significant predictors of organizational effectiveness of the Iraqi public universities.

Chapter five presents the second empirical study which highlights the impact of dynamic capabilities on organizational effectiveness. The empirical results of this study show several key findings: First, analytical results show that sensing capability has no significant impact on organizational effectiveness. The reason underlying this may be that sensing capability impacts indirectly on organizational effectiveness. Second, the analytical results confirm that learning capability significantly affects the organizational effectiveness, which is in line with the suggestions of (Wilhelm et al.,2015) and (Helfat et al,2007). Third, the results show that reconfiguration capability significantly and positively impacts the organizational effectiveness, which is in line with the opinion of (Teece et al.,1997) and (Eisenhardt and Martin, 2000). In

conclusion, the Iraqi public universities can achieve superior organizational effectiveness by using learning capability and reconfiguring capability. Lastly, in chapter six I investigate the mediating role of dynamic capabilities on the relationship between human resource development and organizational effectiveness. This study provides evidence that dynamic capabilities are significantly mediate the relationship between HRD practices and organizational effectiveness which is in line with the opinions (Zollo and Winter 2002; Aminu and Mahmood, 2015). In conclusion, this study argues that the relationship between HRD practices and organizational effectiveness is not direct in changing business environments but through the mediating role of dynamic capabilities. Consequently, in such shifts and turbulences in business environments, organizations need to develop not only human resource but also dynamic capabilities for sensing environmental conditions, learning response patterns and reconfiguring operating routines, in turn, organizations will be able to achieve superior organizational effectiveness.

6.2. Theoretical implications

Regarding to the theoretical contribution, this dissertation tries to address the gap and under-explored issues in the literature in several ways. First, the dissertation contributes to the emerging knowledge on the linkage between human resource development and organizational effectiveness through providing an empirical model which shows that HRD practices significantly impact on organizational effectiveness. Second, this dissertation attempts to understand and empirically test the relationship between dynamic capabilities and organizational effectiveness. Third, the study empirically supports the mediating effect of dynamic capabilities on the relationship between HRD practices and organizational effectiveness. Despite of that HRD, dynamic capabilities and organizational effectiveness have attracted considerable attention in the literature but, only very limited studies have highlighted the

mediating role of HRD capabilities in the relationships between HRD and organizational effectiveness. Therefore, the empirical findings of this study have potential significance to fill the gap in the literature. Fourth, this dissertation sought to understand and empirically measure three critical managerial and organizational processes. This study determined the HRD practices in four measured dimensions i.e. talent development, training and development, organizational development and career development. Dynamic capabilities were measured in three dimensions: sensing capability, learning capability, and reconfiguration capability which are explicit constructs. Organizational effectiveness was measured in three approaches i.e. goal approach, system resource approach, competing values approach. Thus, it shows that these variables are not obscure abstractions that cannot be measured and managed, but specific processes which can be further, theoretically and empirically, explored and, in turn, to understand the nature their nature.

6.3. Managerial implications

Besides the theoretical implications, this dissertation provides key practical implications for universities management. First, this study has confirmed the significance of HRD practices and how they are positively related to organizational effectiveness. The results of this study have potential to help the decision-makers of universities to develop effective HRD practices which will enable them to improve employees' competencies in enhancing organizational effectiveness. Second, this dissertation sought to help decision-makers of universities on how to build and develop dynamic capabilities such as acquire new knowledge and integrate it into the existing structures through learning capability and how to create new capabilities, rebuild resources and organizational structures to address the environmental turbulence through reconfiguration capability, in turn, universities will be able to achieve superior organizational effectiveness. Third, the present study provides significant

insight and demonstrates a good understanding of integration HRD practices, dynamic capabilities, and organizational effectiveness. In rapidly changing environments, HRD is often not enough to support organizational effectiveness. The universities management should develop not only HRD practices but, also adopt dynamic capabilities mechanisms to improve organizational effectiveness.

6.4. Limitations and future research

Despite of the theoretical and managerial contributions, this study has some limitations that need to be addressed in future research as follows:

1. This study focuses on the top ten Iraqi public universities context, which may not be exclusively generalizable to other sectors. Therefore; future research may investigate this phenomenon in other businesses and economic context
2. This study adopts a cross-sectional research method for data collection, which does not allow the researcher to examine the causality of the relationships between the variables in greater depth. Thus, future research should aim to use longitudinal data which could explain the highlighted relationships more insights.
3. This study focuses on four dimensions of HRD, three dimensions of dynamic capabilities and three dimensions of organizational effectiveness. therefore, future research may include other potential dimensions.
4. The results of this study are limited to the instruments used. The research instrument may not have been properly prepared to reflect all the variables of the study.
5. The questionnaire was translated into Arabic since English is the language of the study. The translated version may not have been entirely precise to the original English version.

6. The respondents may not have had sufficient knowledge or information to respond accurately to the survey instrument.
7. The perceptions of respondents may have been influenced by the respondents' positions within their organizations as well as personal goals, employment experience, educational background, and ethnicity.

THE NEW SCIENTIFIC RESULTS

The empirical analysis of structured equation modeling (SEM) has shown several new scientific findings as follows:

- 1.The empirical results show that HRD practices such as talent development, training and development, organizational development and career development have a significant potential to configure in such a way that employees can perform effectively and meet job requirements through improving employees' competencies, in turn, enhance universities' effectiveness.
- 2.The empirical results demonstrate that comprehensive implementation of HRD practices enhances the building of dynamic capabilities within universities to address the rapidly changing in the environments.
- 3.The analytical results confirm that developing the dynamic capabilities of universities in a changing environment is that throughout improving learning capabilities and the reconfiguring activities that help universities to maintain their leadership in innovation-based competitive environments.
- 4.The empirical results validate that developing the dynamic capabilities of universities play a vital role in the integration between HRD and organizational effectiveness in a dynamic environment.

Summary

This dissertation aims to investigate the impact of practices of human resource development i.e. talent development, training and development, organizational development and career development on organizational effectiveness, examine the relationship between the dynamic capabilities i.e. sensing capability, learning capability, and reconfiguration capability and organizational effectiveness and, lastly explore the mediating role of dynamic capabilities on the relationship between human resource development and organizational effectiveness in the selected Iraqi public universities context. This dissertation reviews a general prologue about human resources development, dynamic capabilities, and organizational effectiveness. Additionally, provides analysis and discussion of the literature, the benefits of the literature review and the research gaps.

This study adopted the survey method to collect primary data. The survey was created by the google-forms tool. The web-based questionnaires were distributed through E-mail designed to collect the relevant data from the selected public universities of Iraq including a number of deans, heads of departments, faculty members and principals of the execution units which seems to provide a corresponding sample for conducting data collecting and analyzing. An online questionnaire was distributed to around 342 employees, out of which 215 completed questionnaires were obtained. Data analysis was done by using Statistical Package for Social Science (SPSS) version 23 and the Analysis of Moment Structures (AMOS) software version 24. Descriptive statistics such as the frequency and percentage, mean, standard deviation, were used to provided data summarization of demographic characteristics of respondents. Also, the Pearson correlation coefficient was used to describe the correlations among the variables. To purify the instrument items confirmatory factor analysis (CFA) was carried out to assess the validity and reliability of the instrument by using convergent and discriminant validity. Also, Cronbach's Alpha was used to examine the reliability of the scale items. The

overall model fit was assessed using seven goodness-of-fit indices, and the hypotheses are tested by using structural equation modeling SEM.

To address the research objectives and empirically test the hypotheses this dissertation conducted three empirical studies. The analytical results are presented in chapter five indicate that human resource development i.e. talent development, training and development, organizational development and career development have a significant impact on organizational effectiveness. In chapter six the analytical results show that sensing capability has no have a significant impact on organizational effectiveness. The learning capability and reconfiguration capability are positively and significant influence organizational effectiveness. The empirical results in chapter seven confirm that human resource development practices have direct significant impact on organizational effectiveness. Likewise, human resource development practices have direct significant impact on dynamic capabilities. Also, the dynamic capabilities are significantly mediate the relationship between human resource development and organizational effectiveness.

This dissertation concludes that HRD practices i.e. talent development, training and development, organizational development and career development in the selected Iraqi public universities are positively and significantly influence the organizational effectiveness. Also, it concludes that the selected Iraqi public universities can use learning capability and reconfiguration capability to achieve superior organizational effectiveness rather than focus on sensing capability. lastly, it concludes that in rapidly changing environment the selected Iraqi public universities can adopt dynamic capabilities as mediate variable on the relationship between HRD and organizational effectiveness. Based on the existing literature and empirical results, the dissertation finalizes the new scientific results and provides theoretical and practical implications which are further discussed in detail.

ACKNOWLEDGMENT

I would like to thank my supervisor, Dr. Mezei Cecília, for the patient guidance, encouragement, and willingness to contribute her unique perspectives and knowledge to my work. I have been extremely lucky to have a supervisor who cared so much about my work, and who responded to my questions and queries so promptly.

I would also like to thank Prof. Sándor Kerekes DSc, Prof. Dr. Imre Ferto DSC., Prof. Dr. Zoltán Gál, Dr. György Kövér and all the members of staff at Szent István University - Kaposvár Campus who has provided me extensive personal and professional guidance and taught me a great deal about both scientific research and life in general.

I want to thank the Stipendium Hungaricum Scholarship and Iraqi Scholarship Council for giving me the opportunity to study Ph.D. at Szent István University - Kaposvár Campus.

I want to thank my friends for listening, offering me advice, and supporting me through this entire process.

Last but not the least, nobody has been more important to me in the pursuit of this work than the members of my family. I would like to thank my parents; whose love and guidance are with me in whatever I pursue. They are the ultimate role models. Most importantly, I wish to thank my loving and supportive wife, Hawwa, and my two wonderful children, Saif, and Zaharah, who provide me unending inspiration.

REFERENCES

- Asfaw, A. M., Argaw, M. D. and Bayissa, G. L. (2015). The Impact of Training and Development on Employee Performance and Effectiveness: A Case Study of District Five Administration Office, Bole Sub-City, Addis Ababa, Ethiopia. *Journal of Human Resource and Sustainability Studies*, 3(2): 188-202.
- Abu El Khair, R. H. (2016). Productive university requirements, And their relationship with Organizational effectiveness in technical colleges In Gaza Governorates. Gaza: Al Azhar University.
- Abu Teir, R. A. S. & Ren-Qian Zhang, R. Q. (2016) The current Practices of Human Resource Management in Higher Education institutions in Palestine. *Journal of Human Resources Management and Labor Studies*,4(1):65-83.
- Adhikari, D. R. (2010). Human resource development(HRD) for performance management: The case of Nepalese organizations. *International Journal of Productivity and Performance Management*, 59 (4).
- Agwu, M. O., and Ogiriki, T. (2014). Human Resource Development and Organizational Performance in the Nigeria Liquefied Natural Gas Company Limited, Bonny. *Journal of Management and Sustainability*, 4 (4).
- Alagaraja, M. (2013). Mobilizing organizational alignment through strategic human resource development. *Human Resource Development International*, 16 (1): 74-93.
- Alagaraja, M. (2014). A Conceptual Model of Organizations as Learning-Performance Systems: Integrative Review of Lean Implementation Literature. *Human Resource Development Review*, 13(2): 207–233.
- Alagaraja, M., Cumberland, D., and Choi, N. (2015). The mediating role of leadership and people management practices on HRD and

- organizational performance. *Human Resource Development International*, 18(3):220-234.
- Al-aldaeja, F. M. (2016). The effect of organizational development of the parties participating in King Abdullah II Award on the organizational performance. Algeria: Abu Bakr Blqayd University.
- Al-Essa, A.-R. (2018). Higher Education in Iraq. Baghdad: Minister of Higher Education and Scientific Research.
- Ali Mahfoozi, S. S. (2018). Developing a talent management model using government evidence from a large-sized city, Iran. *Cogent Business and Management*, 5(1).
- Amah, E. (2006). Human Resource Management. Port Harcourt, Nigeria: Amethyst Publishers.
- Ambrosini, V. B. (2009). Dynamic capabilities: An exploration of how firms renew their resource base. *British Journal of Management*, 20(1): 9-24.
- Aminu, M. I., and Mahmood, R. (2015). Mediating Role of Dynamic Capabilities on the Relationship between Intellectual Capital and Performance: A Hierarchical Component Model Perspective in PLS-SEM Path Modeling. *Research Journal of Business*, 9 (3): 443-456.
- Armstrong, M. (2003). Human Resource Management practice. 8th Edition London Boston.
- Asfaw, A. M., Argaw, M. D., and Bayissa, L. (2015). The Impact of Training and Development on Employee Performance and Effectiveness: A Case Study of District Five Administration Office, Bole Sub-City, Addis Ababa, Ethiopia. *Journal of Human Resource and Sustainability Studies*, 3(1):188-202.
- Azari, K. N. (2014). Theories of management and organization in the third millennium. Sari: Mehr Al-Nabi.

- Babelyte-Labanauskė, K., and Nedzinskas, S. (2017). Dynamic Capabilities and their Impact on Research Organizations' R&D and Innovation Performance. *Journal of Modelling in Management*,12(1).
- Balduck, A., and Buelens, M. (2008). A Two-Level Competing Values Approach to Measure Nonprofit Organizational Effectiveness. *Vlerick Leuven Gent Management School Working Paper Series*.
- Banat, M. S. (2002). Organizational Effectiveness of Palestinian Universities The Islamic University of Gaza-A case study. Gaza: The Islamic University of Gaza.
- Barnard, C. (1938). *The Function of the Executive* Cambridge, Mass: Harvard University Press.
- Barney, J. B. (1991). Firm resources and sustained competitive advantage. *Journal of Management*, 17(1): 99–120.
- Baron, R., and Kenny, D. (1986). The Moderator-Mediator Variable Distinction in Social *Psychological* Research: Conceptual, Strategic, and Statistical Considerations. *Journal of Personality and Social Psychology*,51(6): 1173-1182.
- Barreto, I. (2010). Dynamic capabilities: A review of past research and an agenda for the future. *Journal of Management*, 36(1):256–280.
- El Mansour, B. and Dean, J. (2016). Employability Skills as Perceived by Employers and University Faculty in the Fields of Human Resource Development(HRD) for Entry Level Graduate Jobs. *Journal of Human Resource and Sustainability Studies*, 4(2):39-49.
- Bejinaru, R. (2017). Dynamic Capabilities of Universities in the Knowledge Economy. *Management Dynamics in the Knowledge Economy*,5 (4):577-595.
- Bentler, P. (2000). *EQS 6 structural equations program manual*. CA: Multivariate Software Inc.

- Biddix, J. (2014). Instrument, validity, reliability. Research rundowns. Valdosta State University: Dewar College of Education.
- Biswas, M. (2012). Human Resource Management in Hospitality. 1 Jai Singh Road, New Delhi 01: Oxford University Press, YMCA Library Building.
- Bokeno, R. M. (2011). Learning in conflict: revisiting the role of perception", Development and Learning in Organizations. *An International Journal*, 25 (2):15-17.
- Blanco, J. M. M., and Botella, J.-L. M. (2007). Exploring nurtured company resilience through human capital and human resource development: findings from Spanish manufacturing companies. *International Journal of Manpower*,38(5):661-674.
- Brockbank, W. (1999). If HR Were Really Strategically Proactive: Present and Future Directions in HR's Contribution to Competitive Advantage. *Human Resource Management*, 38 (4): 337–352.
- Bruce, M. (2009). Measuring Empowerment. *Leadership and Organization Development Journal*, 24(2):102-108.
- Bayyurt, N. and Rizvi, S. (2015) Impact of talent management on perceived organizational effectiveness: service industry in Lahore, Pakistan. *Research Journal of Business and Management*,2 (4): 468-480.
- Cameron, K. (1980). Critical questions in assessing organizational effectiveness. *Organizational Dynamics*, 9(2):66-80.
- Cameron, K. (1978). Measuring Organization Effectiveness in Institutes of Higher Education. *Administrative Science Quarterly*, 23(4):604- 633.
- Cameron, K. (1981). Domains of organizational effectiveness in colleges and universities. *Academy of Management Journal*, 24(1):25-47.
- Cameron, K. (1986). A study of organizational effectiveness and its predictors. *Management Science*, 32(1):87-112.

- Cameron, K. (1986). Effectiveness as a Paradox: Consensus and Conflict in Conceptions of Organizational Effectiveness." *Management Science*, 32 (5): 539-553.
- Campbell, p. (1977). On the Nature of Organizational Effectiveness: New perspectives on organizational effectiveness. san Francisco: Jossey-pass.
- Capron, L. and Mitchell, W. (2009). Selection capability: How capability gaps and internal social frictions affect internal and external strategic renewal. *Organization Science*, 20(2):294-312.
- Carcary, M., Doherty, D. and Conway G. (2012). The Adoption of Cloud Computing by Irish SMEs – an Exploratory Study. *The Electronic Journal Information Systems Evaluation*,17(1):003-014.
- Carlile, P. (2004). Transferring, translating, and transforming: An integrative framework for managing knowledge across boundaries. *Organization Science*, 15(5): 555-568.
- Carmines, E. G., and Zeller, R. A. (1979). Quantitative Applications in the Social Sciences: Reliability and validity assessment. Thousand Oaks, CA: SAGE Publications, Inc.
- Chang, X. F. (2011). Problems and Suggestions On Human Resources Development of China Enterprise. *International Conference on Management and Service Science*. Wuhan, China: IEEE.
- Chengcheng, J. (2010). The Effect of Human Resource Management Practices on firm's Competitive Advantage: Role of Dynamic Capabilities and Uncertain Environment. *IEEE International Conference on Advanced Management Science*. Chengdu, China.
- Chetana, N., and Mohapatra, A. K. (2016). Effect of Organizational Learning Culture on Career Development Competencies. *International Journal of Research in IT and Management*, 6(10): 19-31.

- Chmielewski, D. A., and Paladino, A. (2007). Driving a Resource Orientation: Reviewing the Role of Resource and Capability Characteristics. *Management Decision*, 45(2) 462-483.
- Clardy, A. (2008). The strategic role of human resource development in managing core competencies. *Human Resource Development International*, 11 (2):183-197.
- Collins, C. J., and Clark, K. D. (2003). Strategic human resource practices, top management team social networks and firm performance: The role of human resource practices in creating organizational competitive advantage. *Academy of Management Journal*, 46(6):740-751.
- Cooper, D. R., and Schindler, P. S. (2011). *Business Research Methods*. (11th edition). California: MacGraw Hill.
- Creswell, J. W. (2013). *Research design: Qualitative, quantitative, and mixed methods approaches* (2nd ed.). Thousand Oaks, CA: Sage.
- Daft, R. (1992). *Organization Theory and Design*. New York: West Publishing Company.
- Danneels, E. (2012). Second-order competences and schumpeterian rents. *Strategic Entrepreneurship Journal*, 6(1):42–58.
- Dobrai, K., and Farkas, F. (2015). The Relationship Between Individual And Organizational Development – Findings Of A Large Sample Research: Hungarian Scientific Research. <https://pdfs.semanticscholar.org/278c/c898898f16ebb7ba076fd862e%E2%80%8E250dbd8c455.pdf>. (Accessed: 15.05.2018)
- Duarte, P., and Raposo, M. (2010). *A PLS Model to Study Brand Preference: An Application to the Mobile Phone Market*. Berlin: Springer.
- Eisenhardt, K. M., and Martin, J. A. (2000). Dynamic capabilities: What are they? *Strategic Management Journal*, 21(10):1105–1121.

- Emeagwal, L.; Ogbonmwan, K.O. (2018). Mapping the perceived role of strategic human resource management practices in sustainable competitive advantage. *Acad. Strateg. Manag. J.* 17, 1–9.
- Fainshmidt, S., Pezeshkan, A., Frazier, M. L., Nair, A., and Markowski, E. P. (2016). Dynamic Capabilities and Organizational Performance: A Meta-Analytic Evaluation and Extension. *Journal of Management Studies*, 53(8):1348-1380
- Federman, M. (2006). Towards an effective theory of organizational effectiveness. http://whatisthemessage.blogspot.com/2006_03_01_archive.html. (Accessed: 05.06.2018).
- Fitzgerald, M. (2014). Talent and Talent Management Insights. NHS Leadership Academy.
- Fornell, C., and Larcker, D. (1981). Structural equation models with unobservable variables and measurement error: Algebra and statistics. *Journal of marketing research*, 18(3):382-388
- Gallardo, F. O., and Navarro, J. R. (2003). A Model of Strategic Change: Universities and Dynamic Capabilities. *Higher Education Policy*, 6(1): 1 – 14.
- Gallardo, E., Dries, N., and Tomás F., G.-C. (2013). What is the meaning of ‘talent’ in the world of work? *Human Resource Management Review*, 23(4):290–300.
- Galunic, D. C., and Eisenhardt. (2001). Architectural innovation and modular corporate forms. *Academy of Management Journal*, 44(6): 1229-1249.
- Garavan, T. (2007). A Strategic Perspective on HRD. *Advances in Developing Human Resources*, 9(1): 11–30.
- Garavan, T. N., and Morley, M. (2000). Contemporary HRD research: a triarchy of theoretical perspectives and their prescriptions for HRD. *Journal of European Industrial Training*, 24(3):65-93.

- Garavan, T. N., Shanahan, V., Carbery, R., and Watson, S. (2016). Strategic human resource development: Towards a conceptual framework to understand its contribution to dynamic capabilities. *Human Resource Development International*, 19(4): 289-306.
- Gberevbie, D. E. (2012). Impact of Human Resource Development and Organizational Commitment on Financial Sector Employees in Nigeria. *Annals of the Alexandru Ioan Cuza University-Economics*, 59 (2):29-41.
- Georgopoulos, B. a., and Tannenbaum. (1957). A study of organizational effectiveness. *American Sociological Review*, 22 (5):534-540.
- Gilley, J. W. (2002). Principles of Human Resource Development (2th ed.). NY. Addison-Wesley publishing company.
- Gold, A., Malhotra, A., and Segars, A. (2001). Knowledge management: an organizational capabilities perspective. *Journal of Management Information Systems*, 18(1):185-214.
- Grant, R. M. (1996). Toward a knowledge-based theory of the firm. *Strategic Management Journal*, 17(2):109-122.
- Gratton, L., and Ghoshal, S. (2005). Beyond best practice. *MIT Sloan Management Review*, 46(3): 49–57.
- Greg G. Wang, J. M. (2017). Means vs Ends: theorizing a definition of human resource development". *Personnel Review*, 46 (6):1165-1181.
- Grohmann, A., and Kauffeld, S. (2013). Evaluating Training Programs: Development and Correlates of the Questionnaire for Professional Training Evaluation. *International Journal of Training and Development*, 17(2):135-155.
- Hair, J. B. (2010). Multivariate Data Analysis. 7th Edition. New York: Pearson.

- Hair, J. F. (2006). *Multivariate data analysis*. Upper Saddle River, NJ: . Pearson Prentice Hall.
- Hair, J. S. (2012). An assessment of the use of partial least squares structural equation modeling in marketing research. *Journal of the academy of marketing science*, 40(3):414-433.
- Hair, J. W. (2010). *Multivariate Data analysis*. London: Pearson Prentice Hall.
- Hammer, M. (2001). *The agenda: What every business must do to dominate the decade*. NY: Crown Publishers.
- Hamadamin, H. H. and Atan, T. (2019) The Impact of Strategic Human Resource Management Practices on Competitive Advantage Sustainability: The Mediation of Human Capital Development and Employee Commitment. *Sustainability*, 11, 5782.
- Han, J., Chao, P., Chao, M. and Wright, P. (2006). The HR Competencies-HR Effectiveness Link: A Study in Taiwanese High-Tech Companies. *Human Resource Management*, 45 (3): 391–406.
- Hansen, N. K., and Güttel, W. H. (2014). Human Resource Management Systems, Dynamic Capabilities, and Environmental Dynamics: A Practice-Theoretical Analysis.3(1).
- Harb, I. (Special Report 195, January 2008). Higher Education and the Future of Iraq. <http://www.usip.org/pubs/specialreports/sr195.pdf>: United States Institute of Peace. (Accessed: 12.07.2017).
- Hassan, A. (2007). Human resource development and organizational values. *Journal of European Industrial Training*, 31 (6):435-448.
- Helfat, C. E., and Peteraf, M. A. (2009). Understanding dynamic capabilities: Progress along a developmental path. *Strategic Organization*, 7 (1):91–102.
- Helfat, C. F., Finkelstein, S., Mitchell, W., Peteraf, M., Singh, H., Teece, D., and Winter, S., G. (2007). *Dynamic Capabilities: Understanding Strategic Change in Organizations*. Oxford: Blackwell Publishing.

- Henson, R. K., and Roberts., J. K. (2006). Use of Exploratory Factor Analysis in Published Research Common Errors and Some Comment on Improved Practice. *Educational and Psychological Measurement*, 66 (3): 393–416.
- Hsu, L.-C., and Wang, C.-H. (2012). Clarifying the Effect of Intellectual Capital on Performance: The Mediating Role of Dynamic Capability. *British Journal of Management*, 23(2):179-205.
- Hu, P. (2007). Theorizing strategic human resource development: Linking financial performance and sustainable competitive advantage. *Proceedings of the Academy of Human Resource Development 2007 International Research Conference*. Fayetteville, AR: University of Arkansas.
- Hua, N. (2013). The influence of supervisory and peer support on the transfer of training. *Studies in Business and Economics*, 8(3): 82-97.
- Iansiti, M., and Clark, K. (1994). Integration and dynamic capability: Evidence from product development in automobiles and mainframe computers. *Industrial and Corporate Change*, 3(3): 557-605.
- Ingham, J. (2006). Closing the Talent Management Gap. *Strategic Human Resource Review*,5(3):20-23.
- Jacob, A. D. (2003). “Validation of a short questionnaire to assess the degree of complexity and structuredness of PBL problems. *Medical Education*, 37(4):1001-1007.
- Jacobs, R., and Washington, C. (2003). Employee development and organizational performance: a review of literature and directions for future research. *Human Resource Development International*, 6(2): 343-354

- Janssen, M., and Castaldi, C. and. (2015). Dynamic capabilities for service innovation: conceptualization and measurement. *RandD Management*, 46 (4): 797–811.
- Jantan, H., Hamdan, A. R., and Othman, Z. A. (2009). Classification Techniques for Talent Forecasting in Human Resource Management ". *the 5th International Conference on AdvancedData Mining and Application (ADMA)*, Beijing, China, 496-503.
- Johara, K. (2018). Dynamic Capabilities in Times of Educational Change: The Viewpoint of School Leadership. University of Jyväskylä.
- John Annakis, D. M. (2014). Exploring Factors that Influence Talent Management Competency of Academics in Malaysian GLC's and Non- Government Universities. *Journal of International Business and Economics*, 2(4): 163-185.
- Kareem, M. A. (2017). The Role of Human Resources Development Strategy in Achieving Corporate Social Responsibility: At the SME level. Brno, Czech Republic: 21st European Scientific Conference of Doctoral Students.
- Karim, S. and Capron, L. (2016). Adding, redeploying, recombining and divesting resources and business units. *Strategic Management Journal*, 37(13): 54–62.
- Katou, A. A. (2009). The impact of human resource development on organizational performance: Test of a causal model. *Journal of Behavioral and Applied Management*, 10(1):335-356.
- Kaur, G. (2013). Employee empowerment and organizational effectiveness: A comparative study in public and private and foreign banks in some north Indian states. Punjab: Thapar university.

- Kehoe, R. R., and Wright, P. M. (2013). The impact of high-performance human resource practices on employees attitudes and behaviors. *Journal of Management*, 39(2):366–391.
- Kenny, D. A., and Judd, C. M. (2014). Power Anomalies in Testing Mediation. *Psychological Science*, 25(2):334–339.
- Khan, R. A., Khan, F. A. and Khan, M. A. (2011). Impact of Training and Development on Organizational Performance. *Global Journal of Management and Business Research*, 11(7).
- Kindström, D., and Kowalkowski, C. a. (2013). Enabling service innovation: A dynamic capabilities approach. *Journal of Business Research*, 66 (8): 1063–1073.
- Lado, A., and Wilson, M. (1994). Human resource systems and sustained competitive advantage: a competency-based perspective. *The Academy of Management Review*, 19 (4):669-727.
- Lavie, D. (2006). Capability reconfiguration: An analysis of incumbent responses to technological change. *Academy of Management Review* 31(1): 153-174.
- Lee, D. (2006). Toward away to Enhance Organization Effectiveness. *The Korean Journal of Defence Analysis*, 18(1):135-159
- Lee, M. (2001). A refusal to define HRD. *Human Resource Development International*, 4(3):327-341.
- Lee, S.-M. T.-S. (2014). The effect of knowledge management capability and dynamic capability on organizational performance. *Journal of Enterprise Information Management*, 27(2):158-179.
- Lepak, D. P., and Snell, S. A. (1999). The Human Resource Architecture: Toward a Theory of Human Capital Allocation and Development. *The Academy of Management Review*, 24(1):31-48.

- Lewis, R. a. and Heckman, R. J. (2006). Talent Management: A critical review. *Human Resource Management Review*, 16(2):139–154.
- Li, D. Y. (2014). Dynamic capabilities, environmental dynamism, and competitive advantage: Evidence from China. *Journal of Business Research*, 67(1):2793-2799.
- Leih S and Teece DJ (2016) Campus leadership and the entrepreneurial university: A dynamic capabilities perspective. *Academy of Management Perspectives* 30(2): 182–210.
- López, S. (2005). Competitive advantage and strategy formulation, The key role of dynamic capabilities. *Management Decision*, 43 (5-6): 661-669.
- Lopez-Cabrales, A., Bornay-Barrachina, M., and Diaz-Fernandez, M. (2017). Leadership and dynamic capabilities: the role of HR systems, *Personnel Review*, 46 (2):255-276.
- Lovelock, C., and Wright, L. (2002). *Principles of Service Marketing and Management*. 2ed.
- Lynham, S. (2000). *Organization Development for Performance System*. St. Paul: University of Minnesota Human Resource Development Research Center.
- Lynham, S. A. (2002). Quantitative Research and Theory Building: Dubin's Method. *Advances in Developing Human Resources*, 4(3):242 - 276.
- M, K., W, L., and JR, B. (2011). The role of sampling in clinical trial design. *Psychother Res.*, 21(3):243-51.
- Mafi, S. (2000). Tested the appropriateness of the gap model to the human resource development (HRD) function in organizations. The Ohio State University, USA.
- Mahdi, Z. (1994). *Management of individuals in a quantitative perspective and human relations*. Amman: Dar Majdlawi.

- Mahdi, O.R.; Nassar, I.A.; Almsafir, M.K. (2019). Knowledge management processes and sustainable competitive advantage: An empirical examination in private universities. *J. Bus. Res.* 94, 320–334.
- Mahfoozi, A., Salajegheh, S., Ghorban, M., and Sheikhi, a. A. (2018). Developing a talent management model using government evidence from a large-sized city, Iran. *Cogent Business and Management*, 5(1):1-15.
- Marcoulides, I. G., and Schumacker, R. E. (1998). *Advanced structural equation modeling: Issues and techniques*. Mahwah: Lawrence Erlbaum Associates, Inc.
- Marsick, V., and Watkins, K. (1990). *Facilitating Learning in Organizations: Making Learning Count*. Gower, Aldershot.
- McCracken, M., and Wallace., M. (2000). Exploring Strategic Maturity in HRD – Rhetoric, Aspiration or Reality?’. *Journal of European Industrial Training*, 24 (8): 425–426.
- McGraw, P. (2014). A review of human resource development trends and practices in Australia: Multinationals, locals, and responses to economic turbulence. *Advances in Developing Human Resources*, 1(2): 1-16.
- McKinsey, Q. (2006). An executive take on the top business trends. a McKinsey Global Survey.
- McLagan, P. A., and Suhadolnik, D. (1989). *Models for HRD practice*. the research report ASTD Press, Alexandria, VA.
- Mittal, S. (2013). HRD Climate in Public and Private Sector Banks. *Indian Journal of Industrial Relations*, 49(1):123-131.
- Mohammed, I. (2006). Personnel performance evaluation: A conceptual index for the management and development of Nigerian oil and gas industry. *Petroleum Training Journal*, 3(1):24-31.

- Mu, J. (2017). Dynamic Capability and Firm Performance: The Role of Marketing Capability and Operations Capability. *IEEE Transactions on Engineering Management*, 64(4):554 - 565.
- Muller, D., Judd, C. M., and Yzerbyt, V. (2005). When Moderation Is Mediated and Mediation Is Moderated. *Journal of Personality and Social Psychology*, 89(6):852-63.
- Nadler, L. (1969). The Variety of Training Roles”, American Society of Training and Development. *USA Industrial and Commercial*, 1(1):34.
- Nadler, Z. (2012). *Designing Training Programs* ((2nd ed.). ed.). Hoboken: NJ: Taylor and Francis.
- Namazi, M., and Namazi, N.-R. (2016). Conceptual analysis of moderator and mediator variables in business research. *Procedia Economics and Finance*, 36(4):540 – 554.
- Nieves, J., and Haller, S. (2014). Building dynamic capabilities through knowledge resources. *Tourism Management*, 40 (1):224-232.
- Nilsson, S., and Ellstrom, P. E. (2012). Employability and talent management: challenges for HRD practices. *European Journal of Training and Development*, 36(1): 26-45.
- Noe, R. (2001). *Human Resource Management*. 2nd edition Prentice Hall.
- Olovsson, C., and Lundström, E. (2010). *Dynamic Capabilities A multiple case study on successful entrepreneurs in South Africa*. Umeå School of Business.
- Omayan, M. S. (2005). *Organizational Behavior in Business Organizations*. Oman, Jourdan: Wael Publishing and Distribution.
- Orpen, C. (1994). The effects of organizational and individual career management on career success. *International Journal of Manpower*, 15(3):27–37.

- Osman, L. H., Ismail, A., Nowalid, W. A., and Adnan, N. H. (2014). An empirical study of the relationship between career program and employee outcomes. *Journal of WEI Business and Economics*, 3(2).
- Otoo, F. N., and Mishra, M. (2018). Influence of Human Resource Development (HRD) Practices on Organizational Effectiveness: The Role of Employee Competencies. *International Journal of Management Studies*, 3(1).
- Otoo, F. N., Otoo, E. A., Abledu, G. K., and Bhardwaj, A. (2019). Impact of human resource development (HRD) practices on pharmaceutical industry's performance: The mediating role of employee performance. *European Journal of Training and Development*, 43(2).
- Pallant, J. (2010). *PSS survival manual: a step by step guide to data analysis using SPSS* (4th ed.). Maidenhead: McGraw-Hill.
- Parvaneh, R. (2016). The Relationship of Talent Management and Organizational Development with Job Motivation of Employees. *Acta Universitatis Agriculturae et Silviculturae Mendelianae Brunensis*, 64(2): 653–662.
- Pavlou, P. A., and Sawy, O. A. (2011). Understanding the Elusive Black Box of Dynamic Capabilities. *Decision Sciences Journal*, 42(1):239-273.
- Podsakoff, P. M., and Organ, D. W. (1986). Self-reports in organizational research: Problems and prospects. *Journal of Management*, 12(1): 531–544.
- Prince, B. (2005). Career-focused employee transfer processes. *Career Development International*, 10 (4): 293-309.
- Popescu, M., & Băltărețu, A. (2012). Considerations regarding the role of human resources in Romanian educational process revealed by national education law. *Procedia-Social and Behavioral Sciences*, 46 (2): 3993-3998.

- Protogerou, A., Caloghirou, Y. and Lioukas, S. (2012). Dynamic capabilities and their indirect impact on firm performance. *Industrial and Corporate Change*, 21(3): 615–647.
- Qiang, W., and Qile, H. and. (2013). Explicating dynamic capabilities for corporate sustainability. *EuroMed Journal of Business*, 8 (3):255-272.
- Quinn, R., and Rohrbaugh, J. (1981). A competing values approach to organizational effectiveness. *Public Productivity Review*, 5 (1):122-40.
- Ragaven, T. N. (2016). Human resource development in Mauritius: context, challenges, and opportunities. *European Journal of Training and Development*, 40(4): 210-214.
- Rahman, A. A., Ng, S. I., Sambasivan, M. and Wong, F. (2013). Training and organizational effectiveness: moderating role of knowledge management process. *European Journal of Training and Development*, 37 (5):472-488.
- Rahman, W., Shah, F. A., and Rasli, A. (2015). Use of Structural Equation Modeling in Social Science Research. *Asian Social Science*, 11(4)
- Roodposhti, R. F. (2007). *Activity-Based Management: a dynamic approach to value creation in business economics*. Tehran: Termeh Publication.
- Rodrigues, C. and Melo, A. I.(2013). The Triple Helix Model as Inspiration for Local Development Policies:An Experience-Based Perspective. *International Journal of Urban and Regional Research*, 37(5): 675–87.
- Rao, B. S. (2016). Effect of intellectual capital on dynamic capabilities. *Journal of Organizational Change Management*, 29 (2): 129-149.
- Rao, T. (1985). *Integrated human resource development system*. The 1985 Annual Developing Human Resources. San Diego, CA: University Associates.
- Rao, T. (2007). Is it time to replace HRD managers by knowledge and learning managers? Retrieved from [http://indianmba.com/ Faculty Column /FC525/fc525.html](http://indianmba.com/Faculty Column /FC525/fc525.html).(Accessed: 26.07.2018)

- Rastgoo, P. (2016). The Relationship of Talent Management and Organizational Development with Job Motivation of Employees *Acta Universitatis Agriculturae et Silviculturae Mendelianae Brunensis* 64(2):653-662
- Rehman, K. u., and Saeed, Z. (2015). Impact of Dynamic Capabilities on Firm Performance: Moderating Role of Organizational Competencies. *Sukkur Journal of Business Administration*, 2(2):18-40
- Riordan, C. M., Vandenberg, R. J., and Richardson, H. A. (2005). Employee involvement climate and organizational effectiveness. *Human Resource Management*, 44(4):471–488.
- Eisenberger, R., Rhoades, L. and Cameron, J. (1999). Does Pay for Performance Increase or Decrease Perceived Self-Determination and Intrinsic Motivation? *Journal of Personality and Social Psychology* 77(5):1026-1040.
- RM, H., and K., C. (1990). Architectural innovation: the reconfiguration of existing product technologies and the failure of established firms. *Administrative Science Quarterly*, 35(3): 9–30.
- Robbins, P. (1990). "Organization theory: Structure Designs and Applications ". Third Edition(Englewood)Cliffs.New Jersey: Prentice-Hall.
- Robbins, S. P. (2003). *Organizational Behaviour*. 10th ed., HallIrc, 5.
- Rojas, R. R. (2000). A review of models for measuring organizational effectiveness among for-profit and nonprofit organizations. *Nonprofit Management and Leadership*, 11(1):97-104.
- Roy, M. H., and Dugal, S. (2005). Using employee gain sharing plans to improve organizational effectiveness. *Benchmarking*, 12 (3): 250-259.
- Ruona, W. (2002). What's in a name? Human resource development and its core. *Proceedings of the Academy of Human Resource Development*, (p. HI.). Honolulu.

- Sabarina, M. (2015). Impact of human resource development strategy on the performance of individuals in universities. Biskra: Mohammed Khaydar University.
- Potnuru, R.K.G.and Sahoo, C. K. (2016). HRD interventions, employee competencies and organizational effectiveness: an empirical study". *European Journal of Training and Development*, 40 (5):345-365
- Schermerhorn, J. R. (2004). Core concepts of organizational behavior. John Wiley and Sons Inc.
- Scheriber, J. B; Stage, F.,K; King, J. (2006). Reporting Structural Equation Modeling and Confirmatory Factor Analysis Results: A Review. *The Journal of Educational Research*, 99(6): 23-337.
- Schreyögg, G., and Kliesch-Eberl, M. (2007). How dynamic can organizational capabilities be? Towards a dual-process model of capability dynamization. *Strategic Management Journal*, 28 (9)913–933.
- Schuler, R. a. (1999). Strategic Human Resource Management. Oxford: Blackwell Publishers.
- Schumacker, R. E. and Lomax, R. G. (2007) A Beginner's Guide to Structural Equation Modeling Third Edition. Taylor & Francis Group, New York
- Schuler, R., and Jackson, S. E. (2014). Human resource management and organizational effectiveness: yesterday and today. *Journal of Organizational Effectiveness: People and Performance*, 1(1): 35-55.
- Sekaran, U. (2003). Research Methods for Business: A Skill-Building Approach. 4th Edition. New York: John Wiley and Sons.
- Sekaran, U., and Bougie, R. (2013). Research Methods for Business: A Skill-Building Approach. 6th Edition. New York.: Wiley.

- Shah, C. R. (2016). Competency Mapping and its impact on Organization Effectiveness with special reference to Sales Staff of Pharmaceutical Industry of Ahmedabad Region. AHMEDABAD: Gujarat Technological University.
- Shanahan, V., Garavan, T., and Carbery, R. (2012). Strategic Human Resource Development and Dynamic Capabilities. *Leadership and Management Development conference*. University Forum for Human Resource Development.
- Simonds, D., and Pederson, C. (2006). HRD: the shapes and things to come. *Journal of Workplace Learning*, 18(2):122-135.
- Sims, R. (2002). Organizational Success through Effective Human Resources Management. Westport CT: Quorum Books.
- Singh, (2015). Employee Motivation and Organizational Effectiveness: An Empirical Study. *Rama university journal*, 1(1):55-62.
- Singleton, D. R. (2014). The Influence of Human Resource Development on Systemic Practices, Utility, and Organizational Results among Contracting Professionals. Alabama: Columbia Southern University https://papers.ssrn.com/sol3/papers.cfm?abstract_id=2498936.(Access ed:24.04.2018).
- Stephen, M. R. (2016). Investigating the role of Human Resource Development (HRD) policy formulation, implementation, and regulation of academic staff in two case study Nigerian Polytechnic institutions. University of Salford <http://usir.salford.ac.uk/id/eprint/39249/>.(Accessed:25.04.2018).
- Srivastava, M.; Franklin, A.; Martinette, L. (2013). Building a sustainable competitive advantage. *J. Technol. Manag.Innov.* , 8, 47–60.
- Swanson, and A., R. (2001). Human resource development and its underlying theory. *Human Resource Development International*, 4(3): 299-312.

- Swanson, R. A., and Holton. (2001). *Foundations of Human Resource Development*. (3 ed.). San Francisco: Berrett-Koehler.
- Swanson, R., and Holton, E. (2009). *Foundations of Human Resource Development*. 2nd Edition. San Francisco.: Berrett-Koehler.
- Tabachnick, B., and Fidell, L. (2007). *Using Multivariate Statistics* (5th ed.). New York: Allyn and Bacon.
- Tabeel, M. (2013). *Career Planning and its relation to organizational effectiveness. Gaza: Academy of Management and Politics*.
- Taherdoost, H. (2016). Sampling Methods in Research Methodology; How to Choose a Sampling Technique for Research. *International Journal of Academic Research in Management (IJARM)*, 5(2): 18-27.
- Takahashi, A. R., and Giacomini, E. S. (2016). Dynamic capabilities, Marketing Capability, and Organizational Performance. *Brazilian Business Review*, 14(5).
- Tan, C. L., and Nasurdin, A. M. (2011). Human resource management practices and organizational innovation: assessing the mediating role of knowledge management effectiveness. *Electronic Journal of Knowledge Management*, 9(2):155-167.
- Teece, D. J. (2007). Explicating dynamic capabilities: the nature and micro-foundations of (sustainable) enterprise performance. *Strategic management journal*, 28(13):1319-1350.
- Teece, D.J., Pisano, G. and Shuen, A.. (1997). Dynamic capabilities and strategic management. *Strategic Management Journal*, 18 (7):509–533.
- Tomé, E. (2011). Human resource development in the knowledge-based and services driven economy". *Journal of European Industrial Training*, 35 (6):524 - 539.

- Torraco, R. (1999). Advancing our understanding of performance improvement. Baton: Academy of Human Resource Development.
- Torrington, D., and Hall, L. (2007). Personnel Management: A New Approach. London.: Prentice-Hall International.
- Tsang-Kai, H. (2010). An empirical study of the training evaluation decision-making model to measure training outcome. *International Journal of Social Behavior and Personality*, 38(1): 87-101.
- Tseng, C.-C., and McLean, G. N. (2008). Strategic HRD practices as key factors in organizational learning. *Journal of European Industrial*, 32(6): 418-432.
- UNESCO. (2004). *Iraq: Education in Transition, Needs and Challenges*. Paris <http://unesdoc.unesco.org/images/0013/001386/138665e.pdf>: UNESCO. (Accessed:10.04.2018)
- Walker, D. (2010). A Confirmatory Factor Analysis of the Attitudes Toward Research Scale Multiple Linear Regression. *Viewpoints*,36(1).
- Wang, Y.-P.-S.; Jaw, B., S. and Tsai, C., H. (2012). Building dynamic strategic capabilities: a human capital perspective. *International Journal of Human Resource Management*, 23(6): 1129-1157.
- Wang, G., and Swanson, R. (2008). The idea of national HRD: an analysis based on economics and theory development methodology. *Human Resource Development Review*, 7(1):79-106.
- Weil, A., and Woodall, J. (2005). HRD in France: the corporate perspective. *Journal of European Industrial Training*, 29(7):529–540.
- Weng, Q., and McElroy, J. C. (2012). Organizational career growth, affective occupational commitment, and turnover intentions. *Journal of Vocational Behavior*, 80(3):256–265.

- Wilden, R. G. Siegfried, P. G, Nielsen, B. B. and Lings, I. (2013). Dynamic capabilities and performance: strategy, structure, and environment. *Long Range Planning*, 46(4):72-96.
- Wilhelm, H., Schlömer, M., and Maurer, I. (2015). How Dynamic Capabilities Affect the Effectiveness and Efficiency of Operating Routines under High and Low Levels of Environmental Dynamism. *British Journal of Management*, 26(2):327-345.
- Wolfe, R., and Putler, D. (2002). How tight are the ties that bind stakeholder groups? *Organization Science*, 13(1): 64-80.
- Wright, P. M., and Snell, S. A. (2009). 'Human resources, organizational resources, and capabilities' in Storey, J. (ed.), *The Routledge companion to strategic human resource management*. London: Routledge, pp. 345-356.
- Wright, P. M., Dunford, B. B., and Snel, S. A. (2001). Human resources and the resource-based view of the firm. *Journal of Management*, 27(1):701–721.
- Xueling, P. (2017). Empirical Study of Career Management and Engagement. *Canadian Social Science*, 13(1):43-48.
- Yan, G., and Gao, E. (2016). Dynamic Capabilities Enhancing Path: a Perspective on Human Resource Policy. *6th International Conference on Management, Education, Information and Control*. Shenyang, China: Atlantis Press.
- Yuan,C. ; Li, Y. ; Vlas, C., O. and Peng, M., W. (2016). Dynamic capabilities, subnational environment, and university technology transfer. *Strategic Organization*, 16 (1) : 35-60.
- Zadeha, L. K., and Ghahremanib, M. (2016). Factors affecting organizational development (Case Study: Welfare office of East Azerbaijan province).

International Academic Journal of Organizational Behavior and Human Resource Management, 3(5):46-51.

- Zhang, J. H, and Li-Zhi, W.(2010). Empirical Study about Applied Relation between Human Resource Development and Advanced Manufacturing Technology. *Proceedings of the International Conference on E-Business and E-Government*. IEEE's Publication Principles.
- Zaina,M. M. H. (2019) Talent Management as a Facilitator of Organizational Intelligence. *Management Science Letters* 9 (1) 809–822
- Zahra, S. A. (2006). Entrepreneurship and dynamic capabilities: A review, model and research agenda. *Journal of Management Studies*, 43(4): 917–955.
- Zahra, S., and George, G. (2002). The net-enabled business innovation cycle and the evolution of dynamic capabilities. *Information Systems Research*, 13(2), 147–155.
- Zhou, S., and Zhou, A. (2017). Dynamic capabilities and organizational performance: The mediating role of innovation. *Journal of Management and Organization*,25(5) p.1- 17.
- Zollo, M., and Winter, S. G. (2002). Deliberate learning and the evolution of dynamic capabilities. *Organization Science*, 13(3):339–351.
- Zott, C. (2003). Dynamic capabilities and the emergence of interindustry differential firm performance: insights from a simulation study. *Strategic Management Journal*, 24(2):97-125.

**PUBLICATIONS RELATED TO THE
TOPIC OF THE DISSERTATION**

Paper in scientific journals

- Kareem, M. A. and Mijbas, H.A (2019). Mediating Role of Dynamic Capabilities on the Relationship between Human Resource Development and Organizational Effectiveness. *Organizacija Journal*, Volume 53, Issue 3. DOI: 10.2478/orga-2019-0012.
- Kareem, M. A., and Hussein, I.J, (2019). The Impact of Human Resource Development on Employee Performance and Organizational Effectiveness: An Empirical Study. *Management Dynamics in the Knowledge Economy Journal*, Vol.7, No.3. DOI 10.25019/MDKE/7.3.02
- Kareem, M. A., and Alameer, A.A. (2019). The Impact of Dynamic Capabilities on Organizational Effectiveness. *Management & Marketing Challenges for the Knowledge Society*. Vol. 14, No. 4, Winter, pp. 402-418 DOI: 10.2478/mmcks-2019-0028.
- Kareem, M. A. (2019). The Impact of Human Resource Development on Organizational Effectiveness: An Empirical Study. *Journal of Management Dynamics in the Knowledge Economy*, 7(1), 29-50, ISSN 2392-8042, DOI 10.25019/MDKE/7.1.02.
- Kareem, M. A., and Mezei, C.(2018). The Role of Human Resource Development on Organizational Effectiveness Considering the Mediating Role of Internal Marketing, *Köztes Európa: társadalomtudományi folyóirat: a Virtuális Intézet Közép-Európa Kutatására közleményei, évfolyam 1. szám*, No. 23, ISSN 2064-437X
- Kareem, M. A. (2017). The Relationship Between Human Resource Management Strategies and Competitive Advantage, *International Journal of Business and General Management (IJBGGM)*; Vol. 6, Issue 5, P.77-86, ISSN(E): 2319-2275.

. Books

Kareem, M. A. (2018). *The Impact of Human Capital on Organizational Innovativeness*, LAP Lambert Academic Publishing, Beau Bassin, Mauritius, ISBN 978-3-659-85852-9.

Full paper in conference proceedings

Kareem, M. A., and Mezei, C. (2017). *The Role of Human Capital Development in Achieving Sustainable Economic Development of Developing countries case study Iraq*, 6th. International Conference of Economic Science, Kaposvár University, Kaposvár, Hungary, ISBN 978-615-5599-42-2.

Kareem, M. A., and Mezei, C. (2017). *The Role of Human Resources Development Strategy in Achieving Corporate Social Responsibility: At SMEs Level*, 21st European Scientific Conference of Doctoral Students, Mendel University in Brno, Czech Republic, ISBN 978-80-7509-555.

Abstract in Conference proceedings

Kareem, M. A. (2019). *The Impact of Dynamic Capabilities on Organizational Effectiveness*. The 2nd Conference of Sustainable Solutions for Growth (SSG), Wrocław, Poland, ISBN

Kareem, M. A. (2018). *Human Capital Development and Regional Development*, 3rd International Young Researcher Scientific Conference “Sustainable Regional Development -Challenges of Space and Society in the 21st Century”, Szent István University, Gödöllő, Hungary, ISBN 978-963-269-730-7.

Kareem, M. A., and Mezei, C. (2018). *The Impact of Human Resource Development on Employee Performance and Organizational Effectiveness: An Empirical Study*, Management International Conference (MIC), Bled, Slovenia, ISBN 978-961-7023-90-9.

Poster in conference

Kareem, M. A. (2019). The Impact of Human Resource Development on Organizational Effectiveness, VIII International Scientific Conference: Contemporary Economic “Social-Economic Problems in Globalization Era – Theory and Practice”, Toruń, Poland.

CURRICULUM VITAE

Mohanad Ali Kareem was born on the 10th of June in 1990 in Najaf, Iraq. He received his bachelor's degree majors in operation management technology from Technical College of Management, Kufa, Iraq, 2012. He obtained his Master's degree in Business Administration (MBA) with a specialization in human resource management and marketing management from Acharya Nagarjuna University, Guntur, India, 2015. During his master's study, he obtained Diploma in Computer Applications from Galaxy Institute of Information Technology, Hyderabad, India, 2014. From 2016 to present, he is doing Ph.D. in management and organizational science at Kaposvar University.

APPENDIX

Questionnaire

Dear Sir/Madam,

We are pleased that you will respond to this online questionnaire (link below). This questionnaire is designed to gather data about the impact human resource development on organizational effectiveness considering the mediating role of dynamic capabilities. The data collected shall be used solely for academic research and shall be treated with strict confidence. It will take about 15-20 minutes to respond to the questionnaire. Your participation in facilitating the study is highly appreciated.

If you have any questions or concerns about completing the questionnaire or about being in this study, please contact me.

Thank you so much for sharing your time and expertise in advance.

Mohanad Ali Kareem. MBA

Ph.D. Student – Faculty of Economic Science, Kaposvar University, Hungary.

E-mail: mohannadali25@gmail.com

Mobile phone: Iraq +9647805347410 or Hungary +36308954011.

General Instructions

- In all cases where answer options are available please tick (✓) in the box provided. And write a text where an underline is.
- For scale typed questions please circle your preferred level of agreement

Section 1: Participant and Institutional background Information

1. Name of university/institution:

2. Gender of respondent

Male Female

3. Age

20-30 30-40 40-50 50- More than 60 years

4. Position held

Dean Assistant Dean Head of the Department
Assistant Head of the -Department

Teaching Staff Administrative Employee
Other.....

5. Work experience in current university/institution (in years):

0-5 5-10 10-15 15-20 More than
20

6. Education level of respondent:

Diploma Bachelor's degree Master's degree
PhD

Other, please specify -----

7. What is the number of employees in your university/institution?

Less than 20 20-49 50-199
300-499

200-299 500 and over

8. What type of ownership is your university/institution?

State-owned Private Limite

Section II: Human resource development: is a systematic process of educating and acquiring new skills, knowledge, and abilities of individual and group through talent development, training and development, career development, and organizational development initiatives.

Please indicate (by ticking (√) the appropriate box) the extent to which you agree or disagree with each of the statements. (0= I don't know ,1 = strongly disagree, 7 = strongly agree).

Statement	0	1	2	3	4	5	6	7
1.Talent Development								
TD1. Our university\institute attracts and recruit the right talent								
TD2. Our university\institute identifies existing talent								
TD3. Our university\institute nurtures and develop talent								
TD4. Our university\institute ensures the talent engagement								
TD5. Our university\institute ensures the talent retention								
2.Training and Development								
TandD1. Our university\institute has effective training and development programs								
TandD2. The activities of training development programs provided enable to improve skills, knowledge, attitude change, new capability of the employee.								
TandD3. The activities of training programs provided help to increase job satisfaction and work efficiency.								
TandD4. Our university\institute uses a modern training and development methods and tools.								
TandD5. Evaluate the trainees' overall satisfaction with the training program.								
Organizational Development								
GD1. Our university\institute makes efforts to development of human resources according to organizational change								
GD2. Our university\institute encourages the change management								

GD3. Our university\institute ensures the organizational restructuring								
GD4. Our university\institute encourages the teamwork								
GD5. Our university\institute encourages the problem-solving culture								
Career Development								
CD1. The organizational structure of the university\institute facilitates the career planning and development								
CD2. Our university\institute offers career counseling.								
CD3. Our university\institute gives training to help develop my career								
CD4. Our university\institute has a fair promotion								
CD5. Our university\institute ensures the growth of remuneration.								

Dynamic Capabilities: The organization 's ability to integrate, build, and reconfigure internal and external competencies to address rapidly changing environments.

Please indicate (by ticking (√) the appropriate box) the extent to which you agree or disagree with each of the statements. **(0= I don't know ,1 = strongly disagree, 7 = strongly agree).**

Statement	0	1	2	3	4	5	6	7
Sensing capabilities								
SC1. Our university\institute conducts environmental assessment to identify new job opportunities								
SC2. Our university\institute ensures the performance assessment								
SC3. our university/institute dedicates much time to applying ideas for new educational programs and improving existing educational programs								
SC4. Our university\institute encourages the collaboration readiness								
SC5. Our university\institute encourages the changing and renewal								

Learning Capabilities								
LC1. Our university\institute has effective routines to identify, value, and import new information and knowledge.								
LC2. Our university\institute has appropriate routines to assimilate new information and knowledge.								
LC3. Our university\institute has effective in transforming existing information into new knowledge.								
LC4. Our university\institute has effective in utilizing knowledge in new services.								
LC5. Our university\institute has effective in developing new knowledge that has the potential to influence service								
Reconfiguration Capabilities								
RC1. Our university\institute has a clear human resource re-allocation procedure								
RC2. Our university\institute makes efforts to organizational response to environmental changes.								
RC3. Our university\institute fasts response to competitor's actions.								
RC4. Our university\institute has an effective communication with cooperative organization.								
RC5. Our university\institute fasts response to changes in the needs of its clients								

Organizational Effectiveness: the ability of an organization to achieve its goals, stability, productivity of the organization, adapt to the changing business environment, workforce development, and optimal utilization of resources.

Please indicate (by ticking (√) the appropriate box) the extent to which you agree or disagree with each of the statements. (0= I don't know ,1 = strongly disagree, 7 = strongly agree).

Statement	0	1	2	3	4	5	6	7
Competing Values Approach								
CVA1. Our university\institute makes efforts to improve the productivity								
CVA2. Our university\institute adapts to the changing environment								
CVA3. Our university\institute makes efforts to the optimization of resources								
CVA4. Our university\institute makes efforts to the stability								
Goal Approach								
GA1. Our university\institute ensures goal achievement								
GA2. Our university\institute has a effective strategic planning								
GA3. Our university\institute encourages the innovation								
GA4. Our university\institute makes efforts improve the quality								
System Resource Approach								
SRA1. Our university\institute has the ability to acquire resource								
SRA2. Our university\institute has good physical infrastructures and equipment								
SRA3. Our university\institute ensure the accreditation								
SRA4. Our university\institute encourages the organizational health								

Section III. Human Resource Development – Concluding Questions

1. Has your university/institute a human resource development strategy?

Yes No No, but the university/institute is planning to do so.

2. In my opinion, the top management believes that human resources are the most valuable organizational resource:

Strongly agree Agree Neut Dis ee
Strongly disagree

3. Do you consider HRD strategy implementation as a key factor in achieving optimal organizational outcome for your university/institute?

Strongly agree Agree Neut Disee
Strongly disagree

4. Personnel policies within my university/institute facilitate employee development.

Strongly agree Agree Neut Disee
Strongly disagree

5. My university/institute conducts regular human resource development programmes for teachers staff.

Strongly agree Agree Neut Disee
Strongly disagree

6. My university/institute conducts regular human resource development programmes for non-teaching staff.

Strongly agree Agree Neut Disee
Strongly disagree

7. Have you ever participated in human resource development programs organized by your university/institute during the past year?

Yes No No, but I'm planning to do so.

8. Participation in human resource development programs offered by my university/institute is useful in performing my job

Strongly agree Agree Neutral Disagree
 Strongly disagree

9. I learn new knowledge and skills through human resource development opportunities offered by my university/institute.

Strongly agree Agree Neutral Disagree
Strongly disagree

10. Overall, use of knowledge and skills gained through development activities increases effectiveness within my organization?

Strongly agree Agree Neutral Disagree
 Strongly disagree